

**Multiple Uses**

Dry Products  
Liquid Products

**Product Codes**

Container: **R16**  
Description: 1-gallon round high performance container

**Cover: T1EG**

Description: Tamper-evident, round cover with tubular gasket

**Features**

Gauge: 65 mil. -  
Nominal capacity: 1 USG / 3.8 L  
Stack performance: 200 lbs.\*  
Tare weights: Body: .485 lbs. / .22 kgs.  
Cover: .22 lbs. / .10 kgs.

Note: \*Ratings will be reduced with uneven load distribution.

**Specifications with Cover**

Dimensions: 8-1/4"D X 7-3/8"H  
Maximum capacity: 1.1 USG / 4.2 L  
Tare weight: .705 lbs. / .32 kgs.

**Colors**

Standard: White, Black and Natural  
Custom: Available at manufacturer's discretion

**Decorating Options**

Four or six\* color offset printing  
Print area: 22-3/4"W X 4-1/2"H  
Sleeve or pressure sensitive labeling

Note: \*Where available

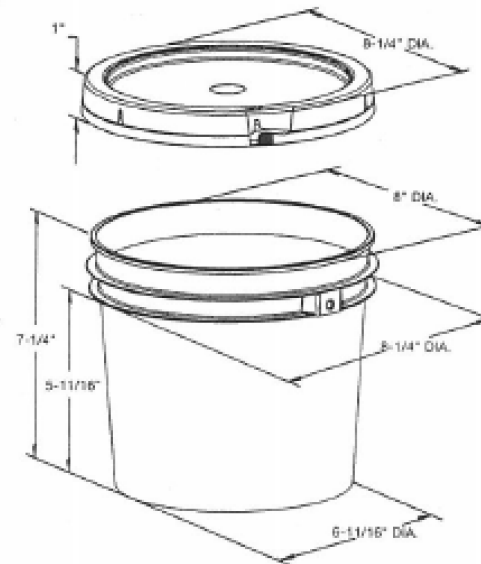
**Shipping Data**

	<b>Bodies</b>	<b>Covers</b>	<b>Filled Containers</b>
Qty. per pallet:	900 (3 packs of 300)	3,000 (5 packs of 600)	180 (30 per layer/6 layers high)
Gross Weight (lbs./kgs.):	436.5/198	660/299	Pallet height: 48"
Length (in./cm.):	51.25/130.2	34.5/87.6	
Width (in./cm.):	43/109.2	53/134.62	
Height (in./cm.):	68.25/173.4	83.75/212.7	
Estimated truckload quantity of 21,000 bodies and covers**			

Notes: \*Weight does not include pallet/packaging

\*\*Truckload quantity based on 53' trailer

**Materials**

FDA approved materials  
Resin: Body: High-Density Polyethylene (HDPE)  
Cover: High-Density Polyethylene (HDPE)  
Styrene Butadiene Rubber (SBR) Gasket  
MSDS Sheets available upon request

**Optional Carrying Handle****DISCLAIMER**

THIS INFORMATION IS PROVIDED AS A GENERAL GUIDE, INCLUDING DIMENSIONS. IT IS THE CUSTOMER'S RESPONSIBILITIES TO SELECT THE PROPER CONTAINER FOR PRODUCT AND APPLICATION COMPATIBILITY.

DISTRIBUTED BY:



REF NO.:

DWG10044

DESCRIPTION:

1 gallon HDPE Open Head Pail