

One Gallon Standard Open Head Plastic Pail

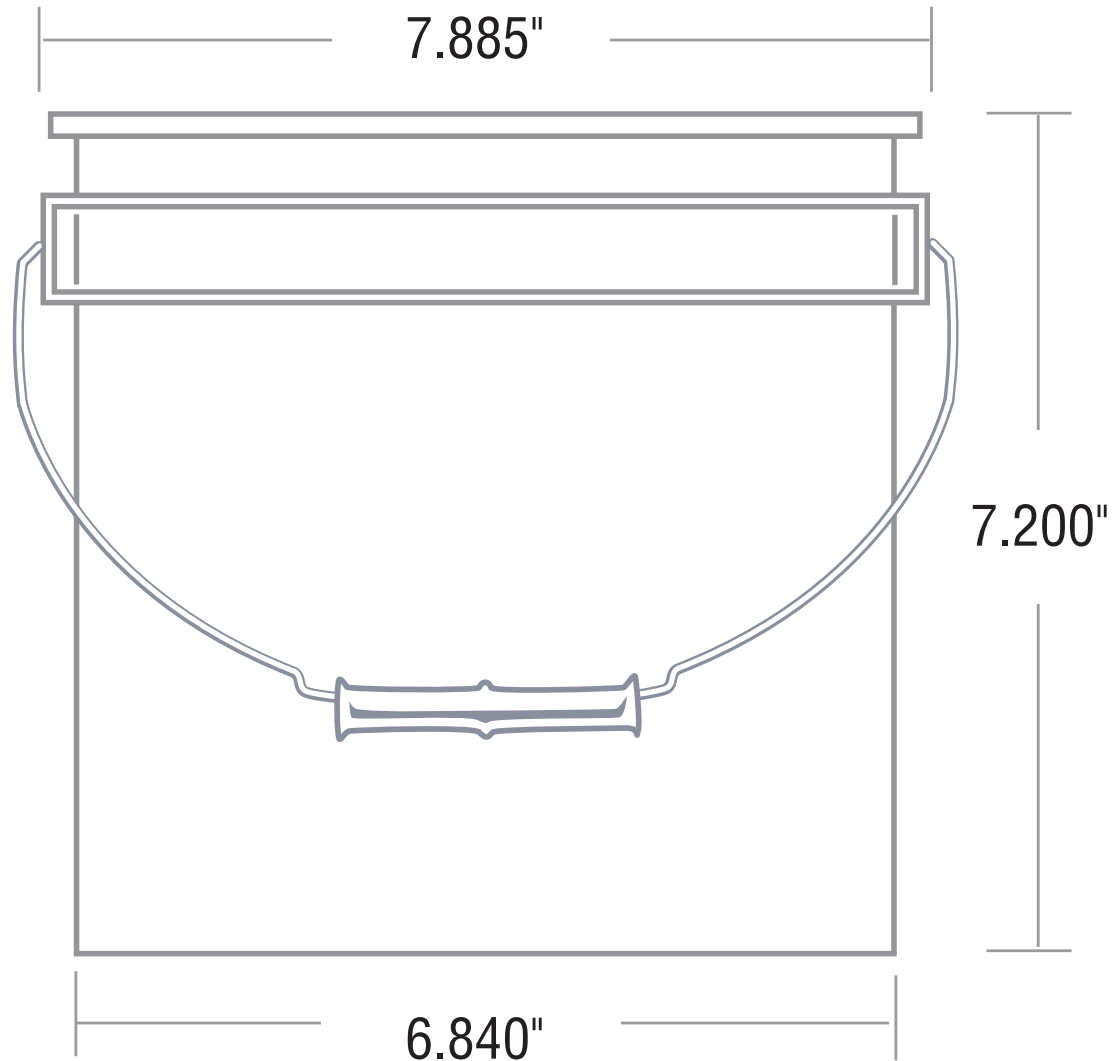

DISCLAIMER

THIS INFORMATION IS PROVIDED AS A GENERAL GUIDE, INCLUDING DIMENSIONS. IT IS THE CUSTOMER'S RESPONSIBILITIES TO SELECT THE PROPER CONTAINER FOR PRODUCT AND APPLICATION COMPATIBILITY.

DISTRIBUTED BY:



REF NO.:

DWG31004

DESCRIPTION:

1 Gallon White HDPE OH Pail, Heavy Weight with Metal Bail & Plastic Grip