

This picture is for illustration purpose only and does not necessarily correspond to the specified product.

Weights and measures

Nominal Capacity	1.000 l	275 gal US
Length	1,200 mm	47.240 in
Width	1,000 mm	39.370 in
Total weight approx.	64.6 kg	142.3 lbs US

Pallet

Pallet type	Steel-framepallet, zincd
Opening height	min. 90mm, 4-way entry

Outer container

Grid	Steel, galvanized
------	-------------------

Case	PE-HD
Connection thread	2"NPS
Flap gasket / Ball gasket	EPDM
Handle color	red, Handle protection
Screw cap	PE-HD
Screw cap gasket	PE, foamed
Screw cap color	black

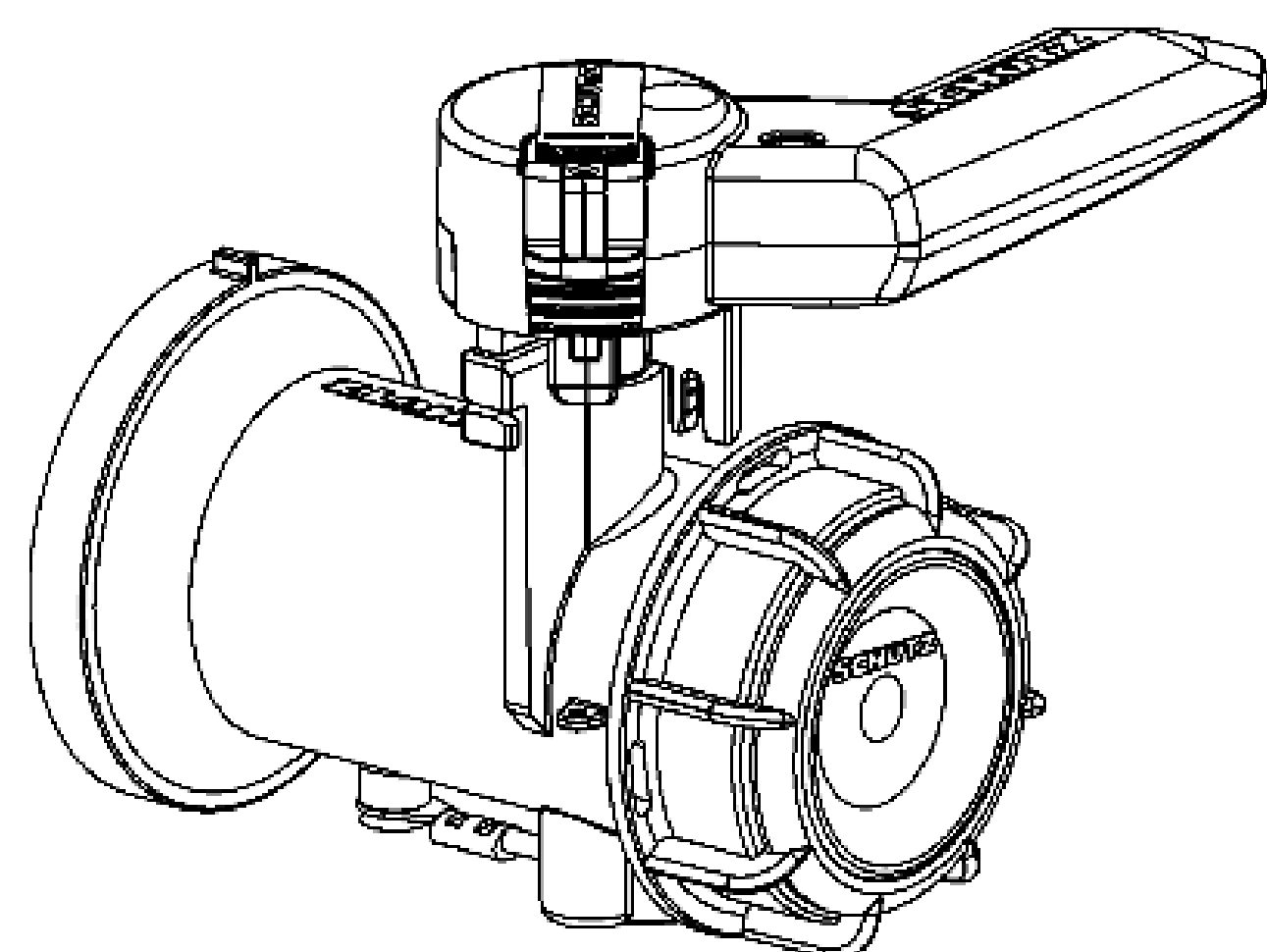

Bottom plate
Label plate
additional label plate

Steel, galvanized
extra large - 8 field
backside extra large - 8 field

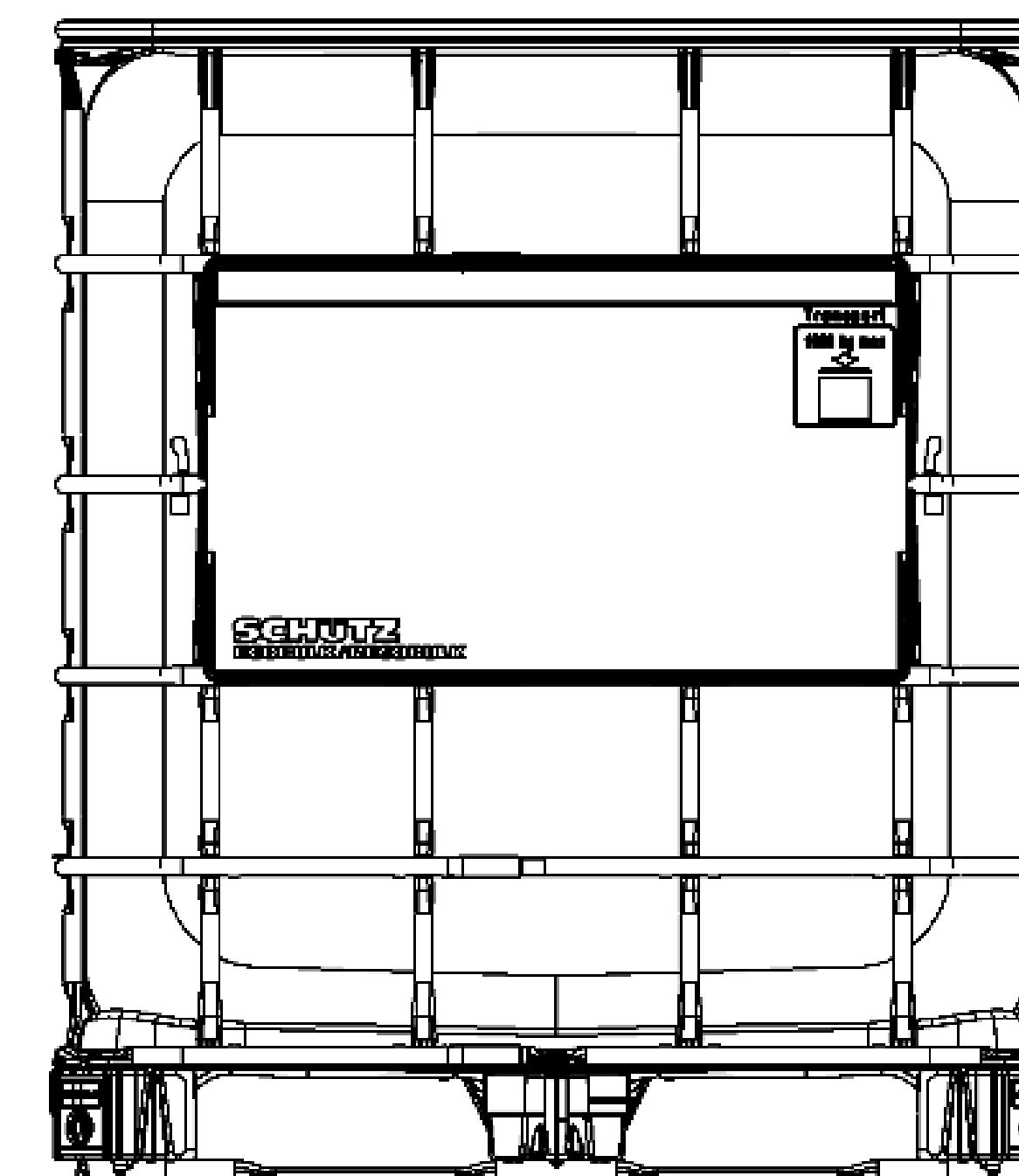
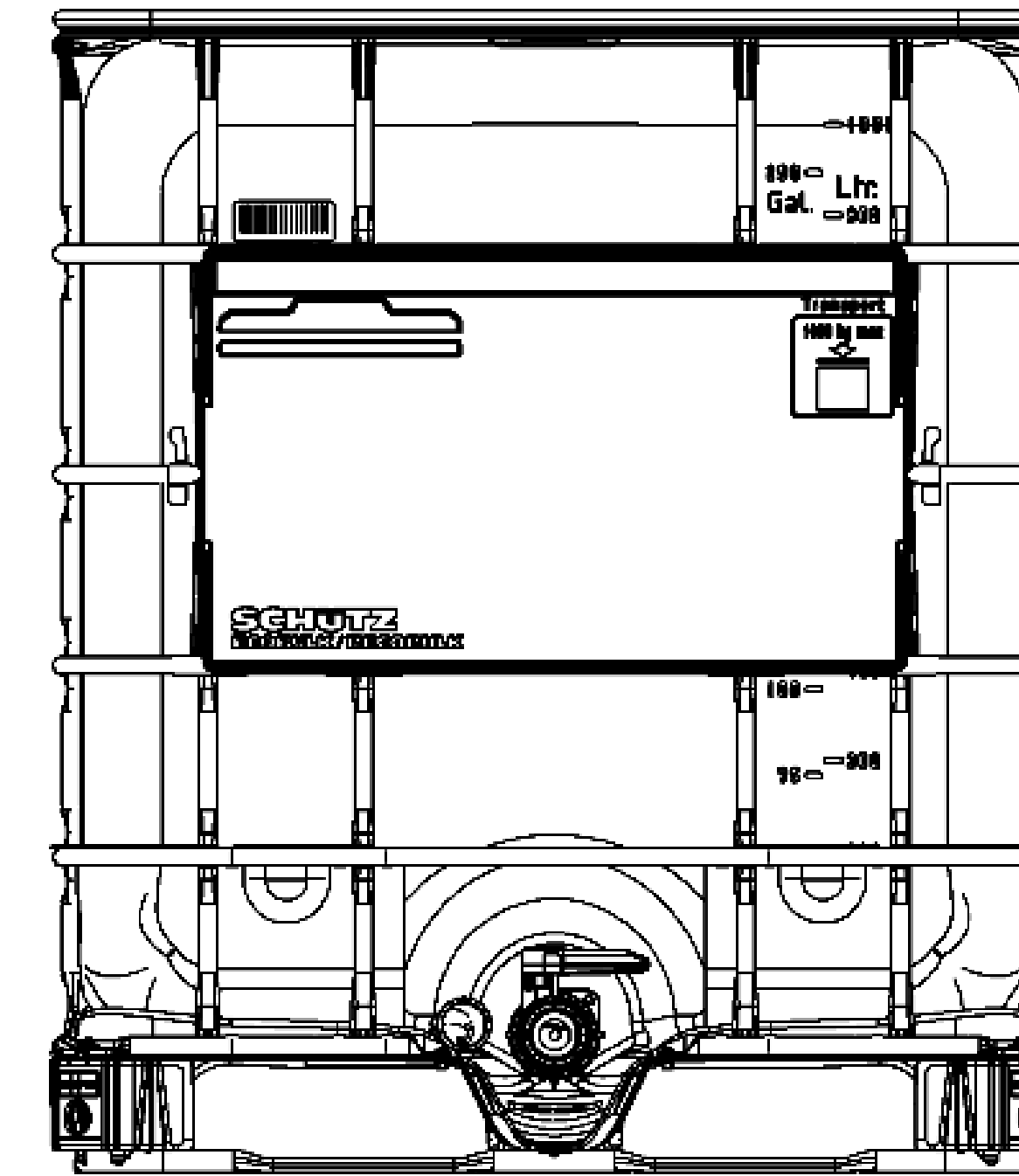

Inner container

Rectangular blow molded tank of high density polyethylene
Container PE-HD, natural

Filling opening

Screw cap DN150 / 6", PE-HD, black
O-ring gasket TPE

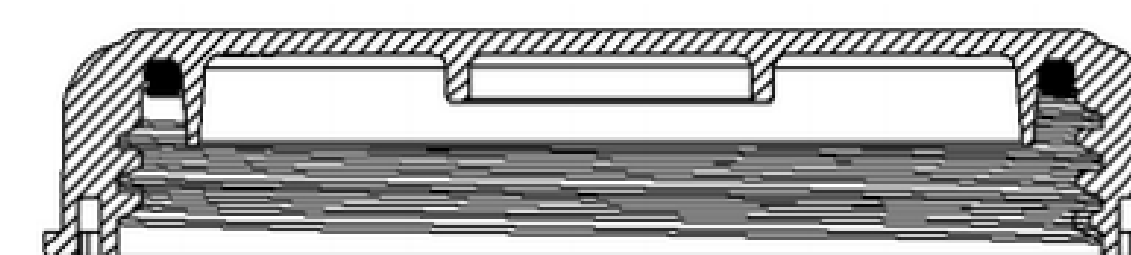

Plug
Discharge opening
Outlet valve

without Plug
ball-valve DN50/2", integrated

DISCLAIMER

THIS INFORMATION IS PROVIDED AS A GENERAL GUIDE, INCLUDING DIMENSIONS. IT IS THE CUSTOMER'S RESPONSIBILITIES TO SELECT THE PROPER CONTAINER FOR PRODUCT AND APPLICATION COMPATIBILITY.

DISTRIBUTED BY:



REF NO.:

DWG30887

DESCRIPTION:

275 Gallon Remanufactured IBC Tote Natural Plastic Bottle with 2" NPT Ball Valve, 6" Plain Fill Cap, No Fitting