

1 Gallon Heavy Duty Round Container

Features

- Heavy duty one gallon
- Reinforcing ribs to maintain container shape
- Tapered design provides for container nesting
- 6 color offset print capability
- Metal handle with grip

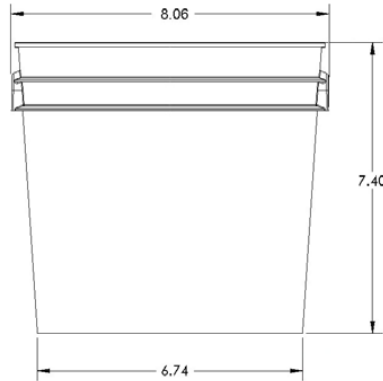

PRODUCT CODE.....1KT01G80W

COMPATIBLE LID..... 1L LO1GGCT (GCTU)

SPECIFICATIONS

Height.....7.40"
 Outer Diameter.....8.06"
 Thickness......80mil
 Print Area.....20.75" x 3.50"
 Resin.....HDPE

VOLUME

Practical Fill.....1.15 gal. / 4.35 liters
 Overflow.....1.22 gal. / 4.62 liters

PACKAGING

Pack Count.....600
 Pack Dimensions.....47.9" x 38.6" x 40.6"
 Cubic Feet.....43.4
 Packs per Pallet.....2

ORDER QUANTITIES (53' Truckload)

1K & 1L 25,200 bases & lids

DISCLAIMER

THIS INFORMATION IS PROVIDED AS A GENERAL GUIDE, INCLUDING DIMENSIONS. IT IS THE CUSTOMER'S RESPONSIBILITIES TO SELECT THE PROPER CONTAINER FOR PRODUCT AND APPLICATION COMPATIBILITY.

DISTRIBUTED BY:



REF NO.:

DWG30277

DESCRIPTION:

1 Gallon HDPE OH Pail