

# 1-Gallon Round Container with FIG EZ Cover®

## Multiple Uses

Dry Products  
Liquid Products

## Product Codes

Container: **R015**  
Description: 1-gallon round can

## Cover: T1FZ

Description: Tamper-evident, round EZ Cover®  
flowed-in gasket

## Features

Gauge: 50 mil.  
Nominal capacity: 1 USG / 3.8 L  
Stack performance: 150 lbs.\*  
Tare weights: Body: .44 lbs. / .20 kgs.  
Cover: .20 lbs. / .09 kgs.

Note: \*Ratings will be reduced with uneven load distribution.

## Specifications with Cover

Dimensions: 8-1/4"D X 7-5/16"H  
Maximum capacity: 1.1 USG / 4.2 L  
Tare weight: .64 lbs. / .29 kgs.

## Colors

Standard: White, Black and Natural  
Custom: Available at manufacturer's discretion

## Decorating Options

Silk - Screening: 20-3/4"W X 4-1/2"H  
Four or six\* color offset printing  
Print area: 22-3/4"W X 4-1/2"H  
Sleeve or pressure sensitive labeling

Note: \*Where available

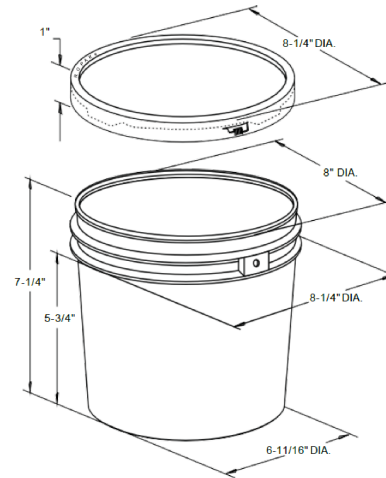

## Shipping Data

|                            | <b>Bodies</b> | <b>Covers</b>           |
|----------------------------|---------------|-------------------------|
| Qty. per pallet:           | 450           | 3,000 (20 boxes of 150) |
| Gross Weight (lbs./kgs.):* | 198/90        | 600/270                 |
| Den. (lbs./C.F./kgs./m3):  | 5.8/92.6      | 6.5/103.1               |
| Length (in./cm.):          | 49.5/125.7    | 50.5/128.3              |
| Width (in./cm.):           | 41.3/104.9    | 42.5/107.9              |
| Height (in./cm.):          | 29/73.7       | 74.5/189.2              |

Estimated truckload quantity of 25,650 bodies and covers\*\*

Notes: \*Weight does not include pallet/packaging  
\*\*Truckload quantity based on 53' trailer

## Filled Containers

180 (30 per layer/6 layers high)  
Pallet height: 48"

## Materials

FDA approved materials  
Resin: Body: High-Density Polyethylene (HDPE)  
Cover: High-Density Polyethylene (HDPE)  
Hot Melt Synthetic Resin – Flowed-in Gasket  
MSDS Sheets available upon request

## Optional Carrying Handle

### DISCLAIMER

THIS INFORMATION IS PROVIDED AS A GENERAL GUIDE, INCLUDING DIMENSIONS. IT IS THE CUSTOMER'S RESPONSIBILITIES TO SELECT THE PROPER CONTAINER FOR PRODUCT AND APPLICATION COMPATIBILITY.

DISTRIBUTED BY:



REF NO.:

DWG10041

DESCRIPTION:

1 gallon White HDPE Open Head Pail