

Multiple Uses

Dry Products
Liquid Products

Product Codes

Container: **R16**
Description: 1-gallon round high performance container

Cover: T1EG

Description: Tamper-evident, round cover with tubular gasket

Features

Gauge: 65 mil. -
Nominal capacity: 1 USG / 3.8 L
Stack performance: 200 lbs.*
Tare weights: Body: .485 lbs. / .22 kgs.
Cover: .22 lbs. / .10 kgs.

Note: *Ratings will be reduced with uneven load distribution.

Specifications with Cover

Dimensions: 8-1/4"D X 7-3/8"H
Maximum capacity: 1.1 USG / 4.2 L
Tare weight: .705 lbs. / .32 kgs.

Colors

Standard: White, Black and Natural
Custom: Available at manufacturer's discretion

Decorating Options

Four or six* color offset printing
Print area: 22-3/4"W X 4-1/2"H
Sleeve or pressure sensitive labeling

Note: *Where available

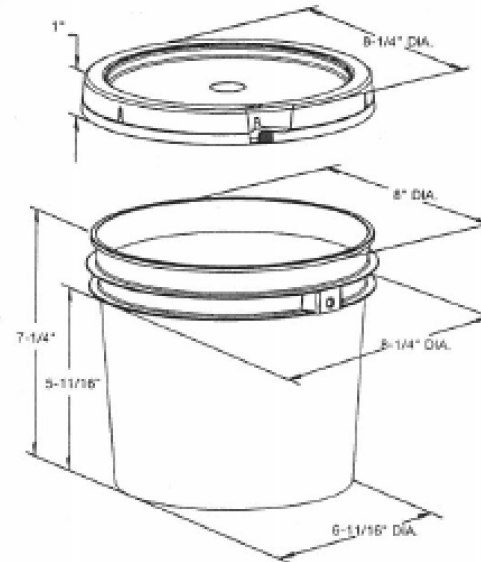
**Shipping Data**

	Bodies	Covers	Filled Containers
Qty. per pallet:	900 (3 packs of 300)	3,000 (5 packs of 600)	180 (30 per layer/6 layers high)
Gross Weight (lbs./kgs.):	436.5/198	660/299	Pallet height: 48"
Length (in./cm.):	51.25/130.2	34.5/87.6	
Width (in./cm.):	43/109.2	53/134.62	
Height (in./cm.):	68.25/173.4	83.75/212.7	
Estimated truckload quantity of 21,000 bodies and covers**			

Notes: *Weight does not include pallet/packaging

**Truckload quantity based on 53' trailer

Materials

FDA approved materials
Resin: Body: High-Density Polyethylene (HDPE)
Cover: High-Density Polyethylene (HDPE)
Styrene Butadiene Rubber (SBR) Gasket
MSDS Sheets available upon request

Optional Carrying Handle**DISCLAIMER**

THIS INFORMATION IS PROVIDED AS A GENERAL GUIDE, INCLUDING DIMENSIONS. IT IS THE CUSTOMER'S RESPONSIBILITIES TO SELECT THE PROPER CONTAINER FOR PRODUCT AND APPLICATION COMPATIBILITY.

DISTRIBUTED BY:



DWG NO.:

DWG10044

DESCRIPTION:

1 gallon HDPE Open Head Pail