

TOP VIEW

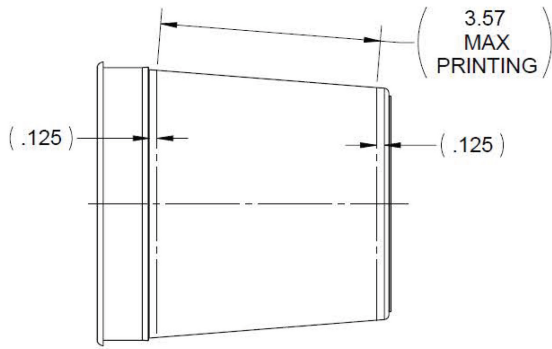

SIDE VIEW

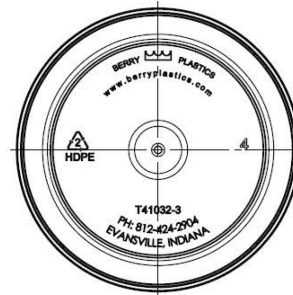

BOTTOM VIEW

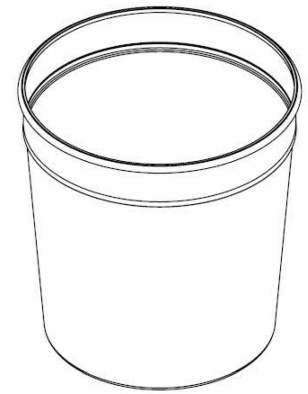

NESTING VIEW

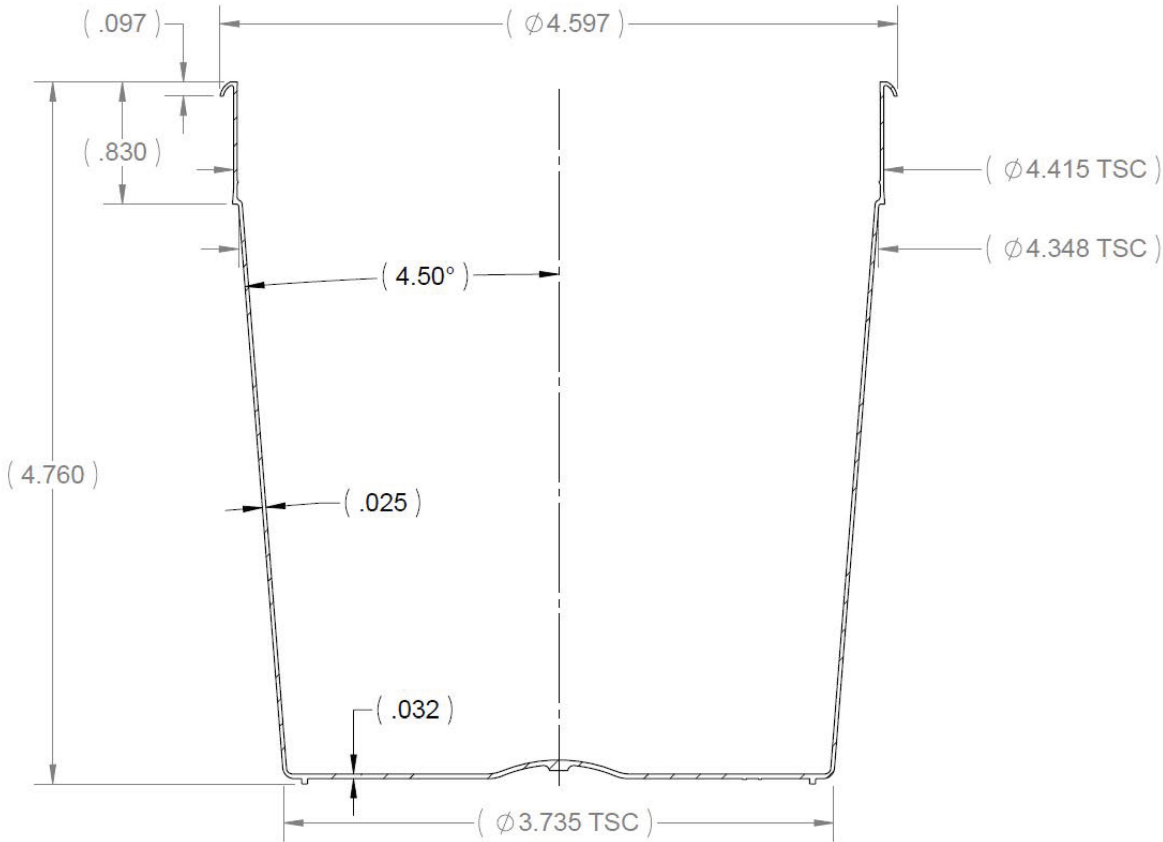

SECTION A-A
SCALE 1 : 1

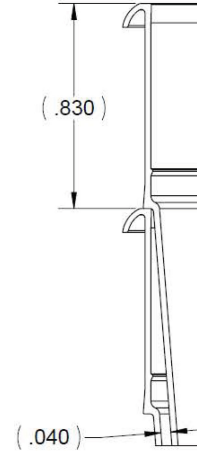

PART DATA	
RESIN FAMILY	HDPE
RESIN DENSITY (GRAMS/CUBIC IN)	15.6
ESTIMATED WEIGHT (CAD MODEL GRAMS)	29.9
VOLUME (CUBIC IN)	60.873
OVERFLOW CAPACITY(OZ)	33.7
OVERFLOW CAPACITY(CC & ML)	997.53
PROJECTED AREA (IN SQ.)	16.6

DISCLAIMER

THIS INFORMATION IS PROVIDED AS A GENERAL GUIDE, INCLUDING DIMENSIONS. IT IS THE CUSTOMER'S RESPONSIBILITIES TO SELECT THE PROPER CONTAINER FOR PRODUCT AND APPLICATION COMPATIBILITY.

DISTRIBUTED BY:



DWG NO.:

DWG20048

DESCRIPTION:

32 oz Translucent PP Tub