

5-Liter EZ STOR® with Gasketless Hinged Cover

Multiple Uses

Dry Products
Liquid Products

Product Codes

Container: **E145**
Description: 5-Liter rectangular can

Cover: **E2AH**

Description: Gasketless, tamper-evident, hinged, EZ open & close cover with Ring Pull®

Features

Gauge: 50 mil.
Nominal capacity: 1.3 USG / 5 L
Stack performance: 125 lbs.*
Tare weights: Body: .46 lbs. / .21 kgs.
Tare weights: Cover: .14 lbs. / .06 kgs.
*Note: *Ratings will be reduced with uneven load distribution.*

Specifications with Cover

Dimensions: 9-13/16" L X 7-11/16" W X 6-7/16" H
Maximum capacity: 1.37 USG / 5.2 L
Tare weight: .60 lbs. / .27 kgs.

Colors

Standard: White, Black, Natural and Clear
Custom: Available at manufacturer's discretion

Decorating Options*

Pressure sensitive labeling
*Note: *See EZ Stor Decoration Summary for further details.*

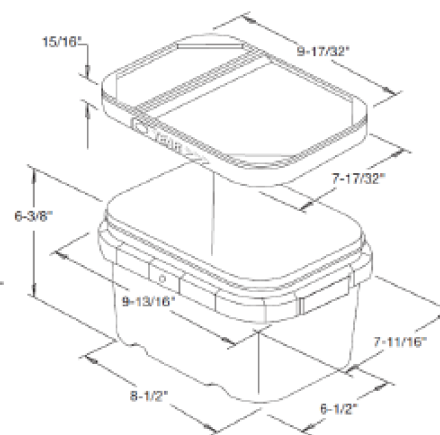

Shipping Data

| | Bodies | Covers |
|--|---------------|---------------|
| Qty. per pallet: | 600 | 1,200 |
| Gross Weight (lbs./kgs.): | 276/126 | 168/72 |
| Den. (lbs./C.F./kgs./m3): | 4.9/78 | 6.6/100.1 |
| Length (in./cm.): | 48/122 | 48/122 |
| Width (in./cm.): | 40/102 | 40/102 |
| Height (in./cm.): | 51/130 | 22.7/57.8 |
| Estimated truckload quantity of 26,400 bodies and covers** | | |

Filled Containers

168 (24 per layer/7 layers high)
Pallet height: 48.882"

*Notes: *Weight does not include pallet / packaging
**Truckload quantity based on 53' trailer*

Optional Carrying Handle

Materials

FDA and HPB approved materials
Resin: Body: Polypropylene (PP)
or Clear Polypropylene (PP)
Cover: Polypropylene (PP)
MSDS Sheets available upon request



Pipeline Packaging

30310 Emerald Valley Pkwy
Glenwillow, OH 44139

| | | | |
|--|------------------|-------------------------|-----------|
| PPC ITEM NUMBER: 52724 | | SKU: 01-05-020-00067 | |
| DRAWN BY: - | CHECKED BY: - | DATE: 11/26/2018 | |
| DESCRIPTION: 1.32 Gal HDPE White Cover Pail | | COLOR: - | |
| PART MATERIAL: - | VOLUME: - | WEIGHT: - | |
| DWG NO.: - | DWG SIZE: A | SHEET NO: 1 of 1 | REV: - |

PROPRIETARY AND CONFIDENTIAL

THE INFORMATION CONTAINED IN THIS DRAWING IS THE SOLE PROPERTY OF PIPELINE PACKAGING. ANY REPRODUCTION IN PART OR AS A WHOLE WITHOUT THE WRITTEN PERMISSION OF PIPELINE PACKAGING IS PROHIBITED.

UNLESS OTHERWISE SPECIFIED:

UNITS OF MEASURE: Inches

TOLERANCES: Specified in drawing