

1.2 Gallon Screw Top ST3 Pail with Cover

Note: *UN Solids rated to Y5.5/S

Multiple Uses

Dry Products

Product Codes

Pail: **9900 Series**

Description: 1.2 Gallon Screw Top Pail

Cover: **8900 Series**

Description: 1.2 Gallon Screw Top Cover

Features

Gauge: 60 mil

Nominal capacity: 1.2 USG / 4.5 L

Stack performance: 350 lbs.*

Tare weights: Body: .62 lbs. / 280 gr.

Cover: .24 lbs. / 110 gr.

Note: *Ratings will be reduced with uneven load distribution.

Specifications with Cover

Dimensions: 8 5/8" D X 8 1/4" H

Maximum capacity: 1.4 USG / 5.3 L

Tare weight: .86 lbs. / .39 kgs.

Colors

Standard: White, Black and Natural

Custom: Available at manufacturer's discretion

Decorating Options

Four color offset printing

Print area: 20 5/8"W X 4-3/4"H

Sleeve or pressure sensitive labeling

Shipping Data

	Bodies	Covers
Qty. per pallet/carton:	1,320*	1,320*
Gross Weight (lbs./kgs.):**:	818.4/371.2	316.8/143.7
Length (in./cm.):	55/139.7	51.25/130.2
Width (in./cm.):	46/116.8	41/104.1
Height (in./cm.):	97/246.4	95/241.3

Approximate truckload quantity of 11,880 pails and covers***

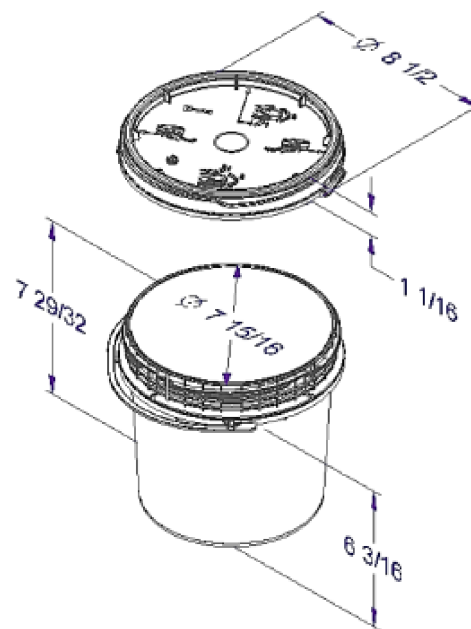

Filled Containers

36 (12 per layer/3 layers high)

Pallet height: 24.75"

Notes:

*Quantity can vary based on customer request

**Weight does not include pallet/packaging

***Based on 53' trailer and full pallet quantities

Materials

FDA approved materials

Resin: Body: High-Density Polyethylene (HDPE)

Cover: High-Density Polyethylene (HDPE)

MSDS Sheets available upon request

Carrying Handle – Molded-in Plastic



Pipeline Packaging

30310 Emerald Valley Pkwy
Glenwillow, OH 44139

PPC ITEM NUMBER:

52835

SKU:

01-05-020-00071

DRAWN BY:

-

CHECKED BY:

-

DATE:

11/26/2018

DESCRIPTION:

1.2 Gal HDPE White Cover Pail

COLOR:

-

PART MATERIAL:

-

VOLUME:

-

WEIGHT:

-

DWG NO.:

-

DWG SIZE:

A

SHEET NO:

1 of 1

REV:

-

PROPRIETARY AND CONFIDENTIAL

THE INFORMATION CONTAINED IN THIS DRAWING IS THE SOLE PROPERTY OF PIPELINE PACKAGING. ANY REPRODUCTION IN PART OR AS A WHOLE WITHOUT THE WRITTEN PERMISSION OF PIPELINE PACKAGING IS PROHIBITED.

UNLESS OTHERWISE SPECIFIED:

UNITS OF MEASURE: Inches

TOLERANCES: Specified in drawing