

# 1-Gallon EZ Stor® Container with Gasketless Hinged Cover

## Multiple Uses

Dry Products  
Liquid Products

## Product Codes

Container: ET14  
Description: 1-gallon tall rectangular can

## Cover: E1AH / E1AR / ETDZ

Description: Gasketless, tamper-evident, hinged, EZ open & close cover with Ring Pull®

## Features

Gauge: 35 mil.  
Nominal capacity: 1.0 USG / 3.8 L  
Stack performance: 60 lbs. dry products\*  
Tare weights: Body: .29 lbs. / .13 kgs.  
Cover: .07 lbs. / .03 kgs.

Note: \*Product designed for use with overpack

## Specifications with Cover

Dimensions: 7-7/8"L X 5-7/8"W X 8-3/16"H  
Maximum capacity: 1.08 USG / 4.09 L  
Tare weight: .36 lbs. / .16 kgs.

## Colors

Standard: White, Black, Natural and Clear  
Custom: Available at manufacturer's discretion

## Decorating Options

Four or six color offset printing\*  
Pressure sensitive labeling  
In-Mold Labeling (IML)

Note: \*Where available

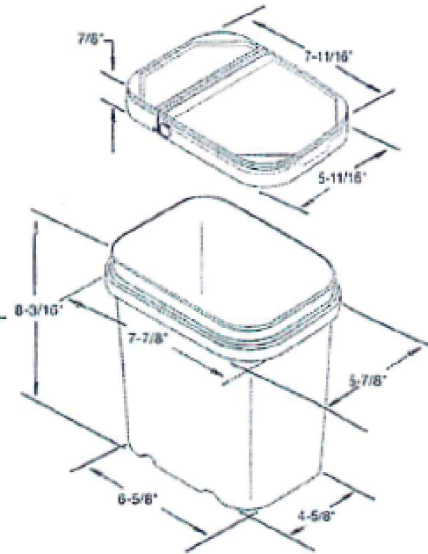

## Shipping Data

	Bodies	Covers	Filled Containers
Qty. per pallet:	1,000	9,000 (18 boxes of 500)	Product designed for use with overpack
Gross Weight (lbs./kgs.):*	290/130	630/270	
Den. (lbs./C.F./kgs./m3):	5.1/81.3	7.2/108	
Length (in./cm.):	50.0/127	50.0/127	
Width (in./cm.):	40.0/101.6	40.0/101.6	
Height (in./cm.):	49.0/124.5	76.0/193.0	
Estimated truckload quantity of 40,000 bodies and covers**			

Notes: \*Weight does not include pallet / packaging  
\*\*Truckload quantity based on 48' trailer

## Optional Carrying Handle

## Materials

FDA and HPB approved materials  
Resin: Body: Polypropylene (PP)  
or Clear Polypropylene (PP)  
Cover: Polypropylene (PP)  
MSDS Sheets available upon request



Pipeline Packaging

30310 Emerald Valley Pkwy  
Glenwillow, OH 44139

PPC ITEM NUMBER: 52513		SKU: 01-05-020-00075	
DRAWN BY:	CHECKED BY:	DATE: 11/26/2018	
DESCRIPTION: 1 Gal HDPE White Cover Pail		COLOR: -	
PART MATERIAL:	VOLUME:	WEIGHT:	
DWG NO.:	DWG SIZE: A	SHEET NO: 1 of 1	REV: -

## PROPRIETARY AND CONFIDENTIAL

THE INFORMATION CONTAINED IN THIS DRAWING IS THE SOLE PROPERTY OF PIPELINE PACKAGING. ANY REPRODUCTION IN PART OR AS A WHOLE WITHOUT THE WRITTEN PERMISSION OF PIPELINE PACKAGING IS PROHIBITED.

## UNLESS OTHERWISE SPECIFIED:

UNITS OF MEASURE: Inches

TOLERANCES: Specified in drawing