

Multiple Uses

Dry Products

Product Codes

Container: E357 Clear

Description: 3.5-gallon rectangular can

Cover: E4DR

Description: Dry seal, tamper-evident, hinged, EZ open & close cover with Ring Pull®

Features

Built in hand grips
 Gauge: 65 mil.
 Nominal capacity: 3.5 USG / 13.2 L
 Stack performance: 150 lbs.*
 Tare weights: Body: 1.12 lbs. / .51 kgs.
 Cover: .38 lbs. / .17 kgs.

Note: *Ratings will be reduced with uneven load distribution.

Specifications with Cover

Dimensions: 12-1/16"L X 10-1/16"W X 11-3/8"H
 Maximum capacity: 3.88 USG / 14.7 L
 Tare weight: 1.50 lbs. / .68 kgs.

Colors

Clear Polypropylene (PP)

Decorating Options*

Four or six color offset printing**
 Sleeve or pressure sensitive labeling
 NXT Graphics®

Note: *See EZ Stor Decoration Summary for further details.

**Where available.

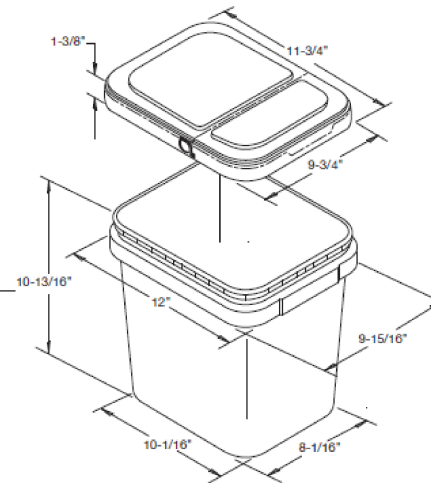
**Shipping Data**

Qty. per pallet: 288
 Gross Weight (lbs./kgs.)**: 322.5/146.8
 Den. (lbs./C.F./kgs./m3): 5.6/91.5
 Length (in./cm.): 48.0/121.9
 Width (in./cm.): 40.0/101.6
 Height (in./cm.): 51.0/129.5
 Estimated truckload quantity of 12,672 bodies and covers***

Bodies

288
 322.5/146.8
 5.6/91.5
 48.0/121.9
 40.0/101.6
 51.0/129.5

Covers

2,304 (32 boxes of 72)*
 875.5/391.6
 10.6/167.6
 47/119.4
 41/104.1
 74/188

Filled Containers

64 (16 per layer / 4 layers high)
 Pallet height: 50"

Note: *Bulkpack of 1120 also available

**Weight does not include pallet / packaging

***Truckload quantity based on 53' trailer

Materials

FDA approved materials
 Resin: Body: Clarified Polypropylene (PP)
 Cover: Polypropylene (PP)
 MSDS Sheets available upon request

Optional Carrying Handle

Pipeline Packaging

30310 Emerald Valley Pkwy
 Glenwillow, OH 44139

PPC ITEM NUMBER:

52504

SKU:

01-05-020-00220

DRAWN BY:

-

CHECKED BY:

-

DATE:

11/20/2018

DESCRIPTION:

3-4.25 Gal HDPE White Cover Pail

COLOR:

-

PART MATERIAL:

-

VOLUME:

-

WEIGHT:

-

DWG NO.:

-

DWG SIZE:

A

SHEET NO:

1 of 1

REV:

-

PROPRIETARY AND CONFIDENTIAL

THE INFORMATION CONTAINED IN THIS DRAWING IS THE SOLE PROPERTY OF PIPELINE PACKAGING. ANY REPRODUCTION IN PART OR AS A WHOLE WITHOUT THE WRITTEN PERMISSION OF PIPELINE PACKAGING IS PROHIBITED.

UNLESS OTHERWISE SPECIFIED:

UNITS OF MEASURE: Inches

TOLERANCES: Specified in drawing