

2.5-Gallon Round Container with Snap-on Cover

Multiple Uses

Dairy Products
Frozen Desserts

Product Codes

Container: **D104**
Description: 2.5 gallon / 10 quart round can

Cover: **D1D0**

Description: Round snap-on cover

Features

Gauge: 45 mil.
Nominal capacity: 2.5 USG / 9.5 L
Stack performance: N/A
Tare weights: Body: .57 lbs. / .26 kgs.
Cover: .15 lbs. / .07 kgs.

Specifications with Cover

Dimensions: 9-3/4"D X 10-1/16"H
Maximum capacity: 2.5 USG / 9.5 L
Tare weight: .72 lbs. / .33 kgs.

Colors

Standard: White and Natural
Custom: Available at manufacturer's discretion

Decorating Options

Four or six* color offset printing
Print area: 28"W X 6-7/8"H
Cover: 6-7/8" Diameter

Note: *Where available

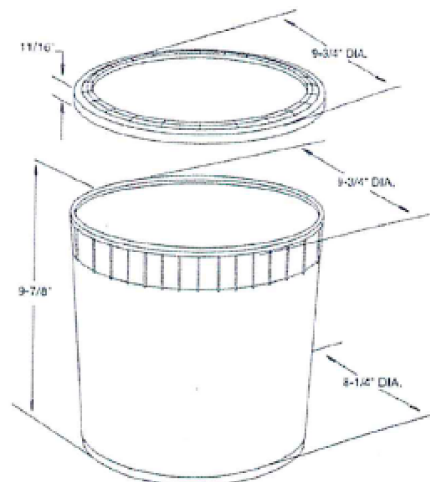

Shipping Data

	<u>Bodies</u>	<u>Covers</u>	<u>Filled Containers</u>
Qty. per pallet:	380	3,200 (16 boxes of 200)	80 (20 per layer/4 layers high)
Gross Weight (lbs./kgs.):	217/99	480/224	Pallet height: 52.6"
Den. (lbs./c.f./kgs./m3):	3.8/61.6	4.6/75.2	
Length (in./cm.):	49.8/126.5	51/129.5	
Width (in./cm.):	40.3/102.4	41/104.1	
Height (in./cm.):	48.8/124	87/220.9	

Estimated truckload quantity of 16,720 bodies and covers.**

Notes: *Weight does not include pallet/packaging
**Truckload quantity based on 53' trailer

Materials

FDA approved materials
Resin: Body: High-Density Polyethylene (HDPE)
Cover: Linear Low Density Polyethylene (LLDPE)
MSDS Sheets available upon request



Pipeline Packaging

30310 Emerald Valley Pkwy
Glenwillow, OH 44139

PPC ITEM NUMBER: 51645		SKU: 01-05-048-00017	
DRAWN BY: -	CHECKED BY: -	DATE: 11/26/2018	
DESCRIPTION: 2.5 Gal HDPE Open Head Pail		COLOR: Natural	
PART MATERIAL: -	VOLUME: -	WEIGHT: -	
DWG NO.: -	DWG SIZE: A	SHEET NO: 1 of 1	REV: -

PROPRIETARY AND CONFIDENTIAL

THE INFORMATION CONTAINED IN THIS DRAWING IS THE SOLE PROPERTY OF PIPELINE PACKAGING. ANY REPRODUCTION IN PART OR AS A WHOLE WITHOUT THE WRITTEN PERMISSION OF PIPELINE PACKAGING IS PROHIBITED.

UNLESS OTHERWISE SPECIFIED:

UNITS OF MEASURE: Inches

TOLERANCES: Specified in drawing