

# 4-Gallon EZ STOR® Container with Hinged Cover

### Multiple Uses

Dry Products

### Product Codes

Container: **E047**

Description: 4-gallon rectangular can

Cover: **E4DH**

Description: Dry seal, tamper-evident, hinged, EZ open & close cover

### Features

- Built in hand grips
- Gauge: 65 mil.
- Nominal capacity: 4.0 USG / 15.1 L
- Stack performance: 150 lbs.\*
- Tare weights: Body: 1.28 lbs. / .58 kgs.
- Cover: .42 lbs. / .19 kgs.

Note: \*Ratings will be reduced with uneven load distribution.

### Specifications with Cover

- Dimensions: 12"L X 9-15/16"W X 12-7/8"H
- Maximum capacity: 4.25 USG / 16.1 L
- Tare weight: 1.70 lbs. / .77 kgs.

### Colors

- Standard: White, Black and Natural
- Custom: Available at manufacturer's discretion

### Decorating Options\*

- Four or six color offset printing\*\*
- Sleeve or pressure sensitive labeling
- NXT Graphics®

Note: \*See EZ Stor Decoration Summary for further details.

\*\*Where available.

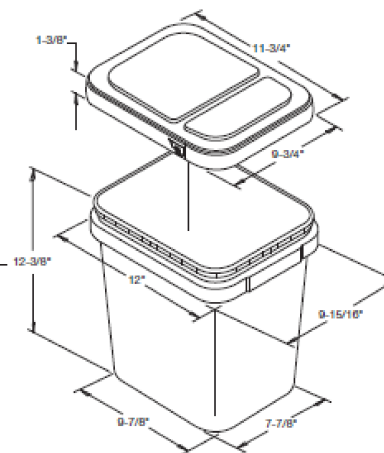

### Shipping Data

	Bodies	Covers	Filled Containers
Qty. per pallet:	288	2,304 (32 boxes of 72)*	48 (16 per layer / 3 layers high)
Gross Weight (lbs./kgs.)**:	369/167	976.6/437.7	Pallet height: 43.5"
Den. (lbs./C.F./kgs./m3):	6.5/104.2	11.7/187.3	
Length (in./cm.):	48.0/121.9	47/119.4	
Width (in./cm.):	40.0/101.6	41/104.1	
Height (in./cm.):	51.0/129.5	74/188	
Estimated truckload quantity of 12,672 bodies and covers***			

Note: \*Bulkpack of 1120 also available

\*\*Weight does not include pallet / packaging

\*\*\*Truckload quantity based on 53' trailer

### Materials

- FDA approved materials
- Resin: Body: High Density Polyethylene (HDPE)
- Cover: Polypropylene (PP)
- MSDS Sheets available upon request

### Optional Carrying Handle



30310 Emerald Valley Pkwy  
Glenwillow, OH 44139

PPC ITEM NUMBER: 51609	SKU: 01-05-048-00096
DRAWN BY: -	CHECKED BY: -
DATE: 11/20/2018	

DESCRIPTION: 4 Gal HDPE Open Head Pail	COLOR: White
PART MATERIAL: -	VOLUME: -
WEIGHT: -	
DWG NO.: -	DWG SIZE: A
SHEET NO: 1 of 1	REV: -

### PROPRIETARY AND CONFIDENTIAL

THE INFORMATION CONTAINED IN THIS DRAWING IS THE SOLE PROPERTY OF PIPELINE PACKAGING. ANY REPRODUCTION IN PART OR AS A WHOLE WITHOUT THE WRITTEN PERMISSION OF PIPELINE PACKAGING IS PROHIBITED.

### UNLESS OTHERWISE SPECIFIED:

UNITS OF MEASURE: Inches

TOLERANCES: Specified in drawing