

3.5 Gallon UN Pail with UN Short Skirt Cover

Note: *Rated for Liquids Y1.5/30 and Solids Y43/S and Solids Y43/S for Packing Group II and III (USA and Canada)

Multiple Uses

Dry Products Pail: 5300 Series
 Liquid Products Description: 3.5 Gallon UN Pail

Cover: 2500 Series
 Description: UN Short Skirt Cover
 Note: *Multiple fitting and venting options available

Features

Gauge: 90 mil
 Nominal capacity: 3.5G / 13.2L
 Stack performance: 350 lbs.*
 Tare weights: Body: 1.6 lbs. / 723 gr.
 Cover: .77 lbs. / 349 gr.

Note: *Ratings will be reduced with uneven load distribution.

Specifications with Cover

Dimensions: 12 5/16"D x 10 3/4"H
 Maximum capacity: 3.6 USG / 13.6 L
 Tare weight: 2.37 lbs. / 1.07 kgs.

Colors

Standard: White, Black and Natural
 Custom: Available at manufacturer's discretion

Decorating Options

Four color offset printing
 Print area: 33"W X 5-3/4"H
 Sleeve or pressure sensitive labeling

Shipping Data

Qty. per pallet/carton: 288*
 Gross Weight (lbs/kgs.)**: 460.8/209
 Length (in./cm.): 50/127
 Width (in./cm.): 38.5/97.8
 Height (in./cm.): 81/205.7
 Approximate truckload quantity of 6,300 pails and covers***

Bodies

1,200
 924/419
 49.5/125.7
 40/101.6
 98/249

Covers

Filled Containers

36 (12 per layer/3 layers high)
 Pallet height: 33"

Notes:
 *Quantity can vary based on customer request
 **Weight does not include pallet/packaging
 ***Based on 53' trailer and full pallet quantities

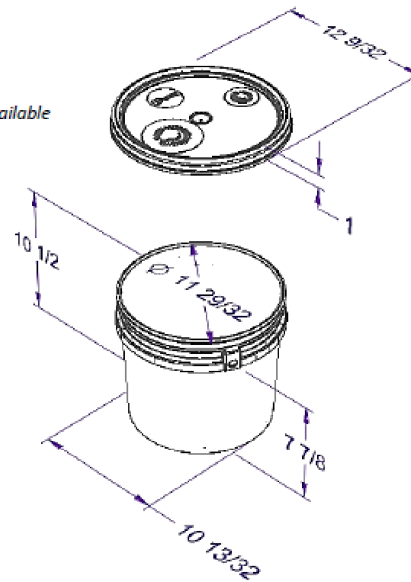

Materials

FDA approved materials
 Resin: Body: High-Density Polyethylene (HDPE) Cover: High-Density Polyethylene (HDPE)
 MSDS Sheets available upon request

Optional Carrying Handle – Wire or Plastic

Pipeline Packaging 30310 Emerald Valley Pkwy
 Glenwillow, OH 44139

PPC ITEM NUMBER: 51444 SKU: 01-05-048-00129
 DRAWN BY: - CHECKED BY: - DATE: 11/19/2018

DESCRIPTION: 3.5 Gal HDPE Open Head Pail COLOR: Black
 PART MATERIAL: HDPE VOLUME: 3.5 Gal WEIGHT: -
 DWG NO.: - DWG SIZE: A SHEET NO: 1 of 1 REV: -

PROPRIETARY AND CONFIDENTIAL
 THE INFORMATION CONTAINED IN THIS DRAWING IS THE SOLE PROPERTY OF PIPELINE PACKAGING. ANY REPRODUCTION IN PART OR AS A WHOLE WITHOUT THE WRITTEN PERMISSION OF PIPELINE PACKAGING IS PROHIBITED.

UNLESS OTHERWISE SPECIFIED:
 UNITS OF MEASURE: Inches
 TOLERANCES: Specified in drawing