

Specifications	IN/LB	MM/KG
Bumper Ring Diameter (D1)	12.3	313
Satellite Ring Diameter (D2)	12.1	307
Curl Diameter (D3)	11.9	303
Base Diameter (D4)	10.3	262
Pail Height (H1)	14.6	371
Bumper Ring (H2)	11.2	285
Pail Weight	2.05	0.93
Overall Package Diameter (D)	12.3	313
Overall Package Height (H)	14.8	376
Overall Package Weight	2.8	1.27
Shipping Information		
Pails per pallet	264	
Covers per pallet	1248	
Pails/Covers per truckload	6600	

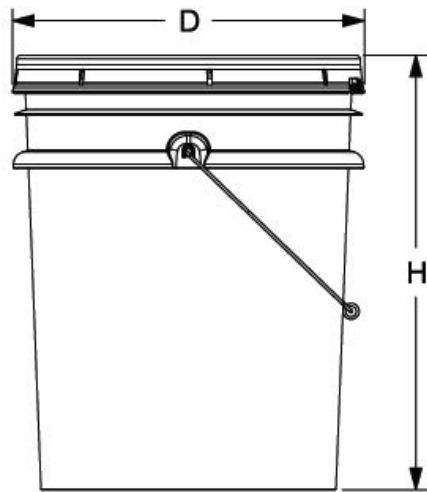

Features & Benefits

- Gauge: 90 mil
- Nominal volume: 5 USG/18.9L
- Material: High-Density Polyethylene (HDPE)
- Maximum capacity: 5.5USG
- Colors: Standard: White, Black, and Natural (Custom colors available upon request)
- Decorating Options: 1 - 6 color offset printing
Heat transfer labels, sleeve or pressure sensitive labeling.
- Print area:
Max Height = 8.5"
Max Length = 33.50"
- Handles Options: 12 ga. Galvanized Steel with HDPE grip, HDPE plastic
- National Motor Freight (NMF) Certification
- Fitting Options: Blank, Tint, Buna

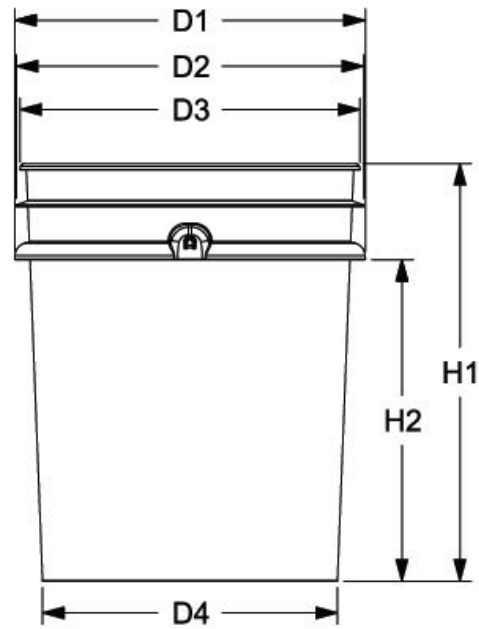

30310 Emerald Valley Pkwy
Glenwillow, OH 44139

PPC ITEM NUMBER: 51766		SKU: 01-05-048-00145	
DRAWN BY: -	CHECKED BY: -	DATE: 11/20/2018	
DESCRIPTION: 5 Gal HDPE Open Head Pail		COLOR: Yellow	
PART MATERIAL: -	VOLUME: -	WEIGHT: -	
DWG NO.: -	DWG SIZE: A	SHEET NO: 1 of 1	REV: -

PROPRIETARY AND CONFIDENTIAL

THE INFORMATION CONTAINED IN THIS DRAWING IS THE SOLE PROPERTY OF PIPELINE PACKAGING. ANY REPRODUCTION IN PART OR AS A WHOLE WITHOUT THE WRITTEN PERMISSION OF PIPELINE PACKAGING IS PROHIBITED.

UNLESS OTHERWISE SPECIFIED:

UNITS OF MEASURE: Inches

TOLERANCES: Specified in drawing