

## 10.7 Gallon Screw Top ST3 Pail with Cover

Note: \*UN Solids rated to Y54.0/5

**Multiple Uses**    **Product Codes**  
 Dry Products    Pail: 9900 Series  
 Description: 10.7 Gallon Screw Top Pail

Cover: 8900 Series  
 Description: 7.7 / 10.7 Gallon Screw Top Cover

### Features

Gauge: 100 mil  
 Nominal capacity: 10.7 USG / 40.5 L  
 Stack performance: 350 lbs.\*  
 Tare weights: Body: 5.5 lbs. / 2,494 gr.  
                   Cover: 1.32 lbs. / 600 gr.

Note: \*Ratings will be reduced with uneven load distribution.

### Specifications with Cover

Dimensions: 15 1/2" D. X 21" H  
 Maximum capacity: 10.8 USG / 40.9 L  
 Tare weight: 6.82 lbs. / 3.1 kgs.

### Colors

Standard: White, Black and Natural  
 Custom: Available at manufacturer's discretion

### Decorating Options

Four color offset printing  
 Print area: 35 6/4"W X 11"H  
 Sleeve or pressure sensitive labeling

### Shipping Data

	Bodies	Covers
Qty. per pallet/carton:	108*	594*
Gross Weight (lbs./kgs.)**:	594/269.4	784/355.6
Length (in./cm.):	47/119.4	47/119.4
Width (in./cm.):	47/119.4	47/119.4
Height (in./cm.):	93/236.2	87/220.9
Approximate truckload quantity of 2,592 pails and covers***		

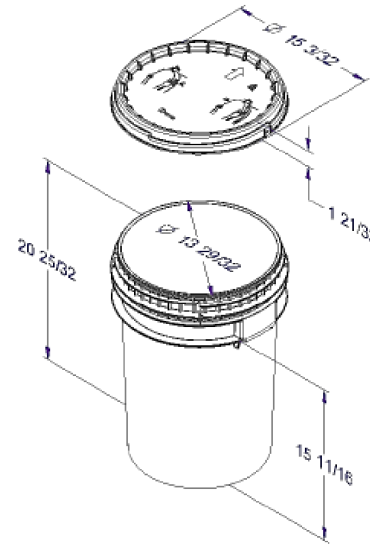

### Filled Containers

36 (12 per layer/3 layers high)  
 Pallet height: 63"

### Notes:

- \*Quantity can vary based on customer request
- \*\*Weight does not include pallet/packaging
- \*\*\*Based on 53' trailer and full pallet quantities

### Materials

FDA approved materials  
 Resin: Body: High-Density Polyethylene (HDPE)  
 Cover: High-Density Polyethylene (HDPE)  
 MSDS Sheets available upon request

Carrying Handle – Molded in grip

		30310 Emerald Valley Pkwy Glenwillow, OH 44139	
		PPC ITEM NUMBER: 51501	SKU: 01-05-048-00235
DRAWN BY: -	CHECKED BY: -	DATE: 11/19/2018	
DESCRIPTION: 10.7 Gal HDPE Open Head Pail		COLOR: White	
PART MATERIAL: HDPE	VOLUME: 10.7 Gal	WEIGHT: -	
DWG NO.: -	DWG SIZE: A	SHEET NO: 1 of 1	REV: -

**PROPRIETARY AND CONFIDENTIAL**

THE INFORMATION CONTAINED IN THIS DRAWING IS THE SOLE PROPERTY OF PIPELINE PACKAGING. ANY REPRODUCTION IN PART OR AS A WHOLE WITHOUT THE WRITTEN PERMISSION OF PIPELINE PACKAGING IS PROHIBITED.

**UNLESS OTHERWISE SPECIFIED:**

UNITS OF MEASURE: Inches

TOLERANCES: Specified in drawing