

12.2 Gallon Screw Top ST3 Pail with Cover

Note: *UN Solids rated to Y59.0/S

Multiple Uses

Dry Products

Product Codes

Pail: 9900 Series

Description: 12.2 Gallon Screw Top Pail

Cover: 8900 Series

Description: 12.2 Gallon Screw Top Cover

Features

Gauge: 100 mil

Nominal capacity: 12.2 USG / 46.2 L

Stack performance: 350 lbs.*

Tare weights: Body: 5.84 lbs. / 2,650 gr.

Cover: 1.45 lbs. / 660 gr.

Note: *Ratings will be reduced with uneven load distribution.

Specifications with Cover

Dimensions: 16 1/8" D. X 21 1/4" H

Maximum capacity: 12.3 USG / 46.5 L

Tare weight: 7.29 lbs. / 3.3 kgs.

Colors

Standard: White, Black and Natural

Custom: Available at manufacturer's discretion

Decorating Options

Four color offset printing

Print area: 36"W X 11 3/4"H

Sleeve or pressure sensitive labeling

Shipping Data

	Bodies	Covers
Qty. per pallet/carton:	108*	594*
Gross Weight (lbs./kgs.)**:	594/269.4	784/355.6
Length (in./cm.):	47/119.4	47/119.4
Width (in./cm.):	47/119.4	47/119.4
Height (in./cm.):	93/236.2	87/220.9
Approximate truckload quantity of 2,592 pails and covers***		

Materials

FDA approved materials

Resin: Body: High-Density Polyethylene (HDPE)

Cover: High-Density Polyethylene (HDPE)

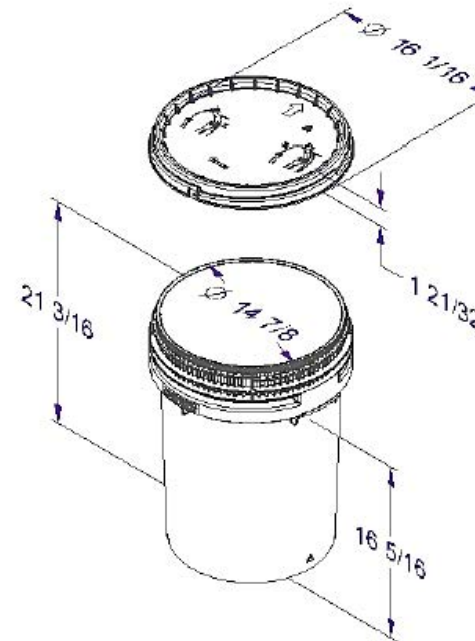

Filled Containers

36 (12 per layer/3 layers high)

Pallet height: 63 5/16"

Notes:

*Quantity can vary based on customer request

**Weight does not include pallet/packaging

***Based on 53' trailer and full pallet quantities



30310 Emerald Valley Pkwy
Glenwillow, OH 44139

PPC ITEM NUMBER: 51503		SKU: 01-05-048-00237	
DRAWN BY: -	CHECKED BY: -	DATE: 11/20/2018	
DESCRIPTION: 12.2 Gal HDPE Open Head Pail		COLOR: White	
PART MATERIAL: HDPE	VOLUME: 12.2 Gal	WEIGHT: -	
DWG NO.: -	DWG SIZE: A	SHEET NO: 1 of 1	REV: -

PROPRIETARY AND CONFIDENTIAL

THE INFORMATION CONTAINED IN THIS DRAWING IS THE SOLE PROPERTY OF PIPELINE PACKAGING. ANY REPRODUCTION IN PART OR AS A WHOLE WITHOUT THE WRITTEN PERMISSION OF PIPELINE PACKAGING IS PROHIBITED.

UNLESS OTHERWISE SPECIFIED:

UNITS OF MEASURE: Inches

TOLERANCES: Specified in drawing