

20.0 Liter Square Tight Head with Integrated Handle

Product Uses

Liquid Products

Product Codes

Square Tight Head: **STH Series**

Multiple Neck Finishes and Vent Options

Features

UN Rating: 3H1/Y1.8/100

Nominal capacity: 5.28 USG / 20.0 L

Maximum capacity: 5.65 USG / 21.40 L

Colors

Standard: White, Black, Blue and Natural

Custom: Available at manufacturer's discretion

Decorating Options

Maximum Print Area:

Perimeter = 38-1/4" X 8-11/16"H

Containers can be decorated; See Salesperson for Options

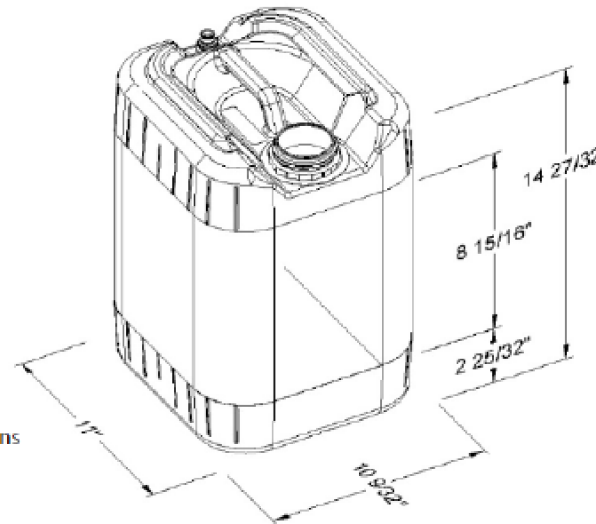

Shipping Data:

Qty. per floor spot*:

Gross Weight (lbs./kgs.)**:

Length (in./cm.):

Width (in./cm.):

Height (in./cm.):

Approximate truckload quantity of 3360 pallets and covers***

Containers

112

306 / 139

44 / 112

33 / 84

107 / 273

Filled Containers

Refer to BWAY document #ETS-CD-1002 for storage and shipping recommendations.

Notes:

*Quantity can vary based on customer request

**Weight does not include pallet/packaging

***Based on 53' trailer and standard pallet quantities

Materials

FDA approved materials

Resin: HDPE

MSDS Sheets and Technical Bulletin available upon request

Handle – Integrated into Body



Pipeline Packaging

30310 Emerald Valley Pkwy
Glenwillow, OH 44139

PPC ITEM NUMBER:

81104

SKU:

01-05-079-00033

DRAWN BY:

-

CHECKED BY:

-

DATE:

2/25/2019

DESCRIPTION:

20 L HDPE Tight Head Pail

COLOR:

Natural

PART MATERIAL:

-

VOLUME:

-

WEIGHT:

-

DWG NO.:

-

DWG SIZE:

A

SHEET NO:

1 of 1

REV:

-

PROPRIETARY AND CONFIDENTIAL

THE INFORMATION CONTAINED IN THIS DRAWING IS THE SOLE PROPERTY OF PIPELINE PACKAGING. ANY REPRODUCTION IN PART OR AS A WHOLE WITHOUT THE WRITTEN PERMISSION OF PIPELINE PACKAGING IS PROHIBITED.

UNLESS OTHERWISE SPECIFIED:

UNITS OF MEASURE: Inches

TOLERANCES: Specified in drawing