

# 4.0 Gallon Rectangular Tight Head with Swing Handle

**Product Uses**

Liquid Products

**Product Codes**

Rectangular Tight Head: **RTH Series**  
Multiple Neck Finishes and Vent Options

**Features**

UN Rating: 3H1/Y1.8/100  
Nominal capacity: 4.0 USG / 15.14 L  
Maximum capacity: 4.25 USG / 16.10 L

**Colors**

Standard: White, Black, Blue and Natural  
Custom: Available at manufacturer's discretion

**Decorating Options**

Maximum Print Area:  
Perimeter = 37-29/32" X 5-29/32"H  
Containers can be decorated; See Salesperson for Options

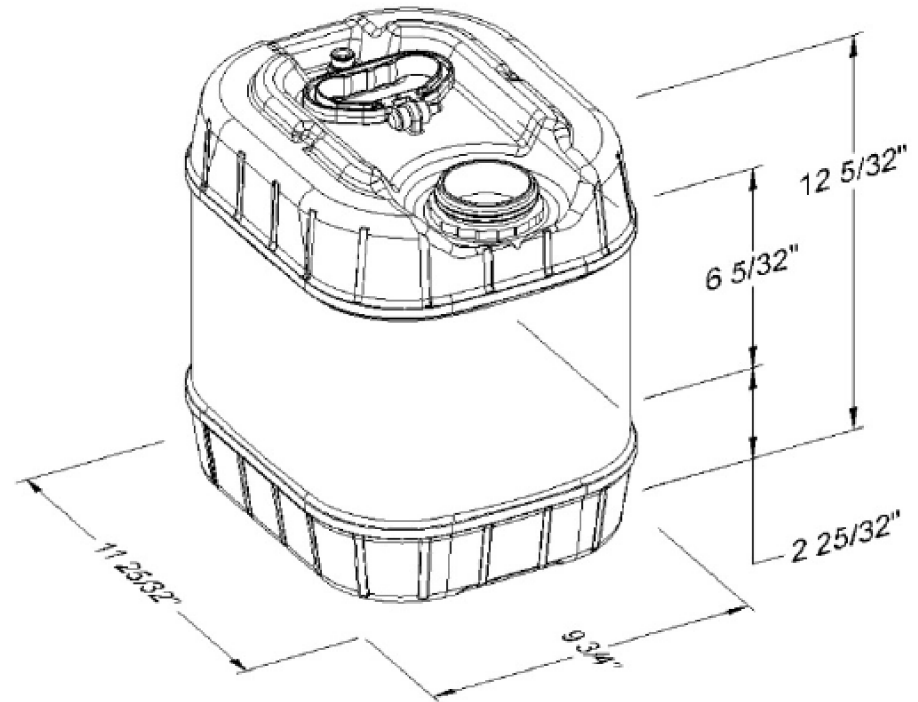

**pipeline Packaging** 30310 Emerald Valley Pkwy  
Glenwillow, OH 44139

PPC ITEM NUMBER: 81167 SKU: 01-05-079-00277

DRAWN BY: - CHECKED BY: - DATE: 2/25/2019

DESCRIPTION: 4 Gal HDPE Tight Head Pail COLOR: Blue

PART MATERIAL: - VOLUME: - WEIGHT: -

DWG NO.: - DWG SIZE: A SHEET NO: 1 of 1 REV: -

**PROPRIETARY AND CONFIDENTIAL**  
THE INFORMATION CONTAINED IN THIS DRAWING IS THE SOLE PROPERTY OF PIPELINE PACKAGING. ANY REPRODUCTION IN PART OR AS A WHOLE WITHOUT THE WRITTEN PERMISSION OF PIPELINE PACKAGING IS PROHIBITED.

**UNLESS OTHERWISE SPECIFIED:**  
UNITS OF MEASURE: Inches  
TOLERANCES: Specified in drawing