

# 10L Tighthead – Standalone

**Product Uses**

Liquid Products

**Product Codes**

Standalone Tighthead

Multiple Neck Finishes and Vent Options

**Features**

UN Rating: 3H1/Y1.8/100

Nominal capacity: 2.64 USG / 10.0 L

Maximum capacity: 2.80 USG / 10.6 L

**Colors**

Standard: White, Black, Natural and Blue

Custom: Available at manufacturer's discretion

**Decorating Options**

Option not available on this product.

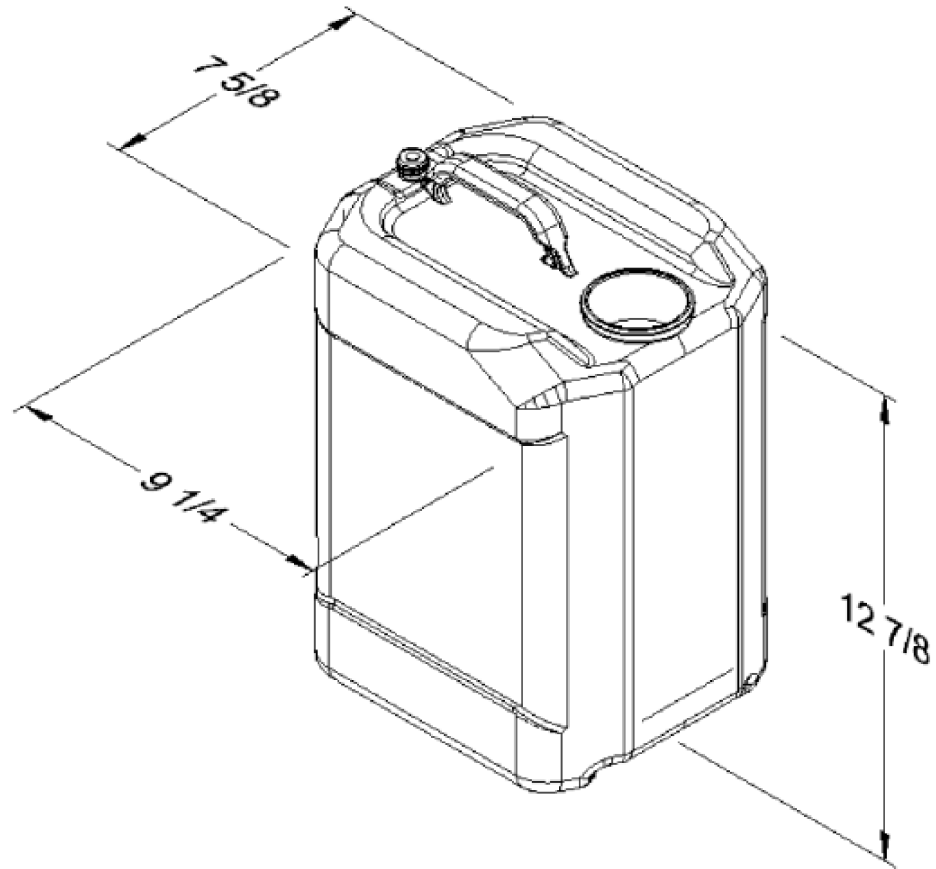

**Pipeline Packaging** 30310 Emerald Valley Pkwy  
Glenwillow, OH 44139

PPC ITEM NUMBER: 81123      SKU: 01-05-079-00322

DRAWN BY: -      CHECKED BY: -      DATE: 2/25/2019

DESCRIPTION: 10 L HDPE Tight Head Pail      COLOR: Natural

PART MATERIAL: -      VOLUME: -      WEIGHT: -

DWG NO.: -      DWG SIZE: A      SHEET NO: 1 of 1      REV: -

**PROPRIETARY AND CONFIDENTIAL**

THE INFORMATION CONTAINED IN THIS DRAWING IS THE SOLE PROPERTY OF PIPELINE PACKAGING. ANY REPRODUCTION IN PART OR AS A WHOLE WITHOUT THE WRITTEN PERMISSION OF PIPELINE PACKAGING IS PROHIBITED.

**UNLESS OTHERWISE SPECIFIED:**

UNITS OF MEASURE: Inches

TOLERANCES: Specified in drawing