

15 gal Tight Head Natural Plastic Drum with 2" and 3/4" Fittings

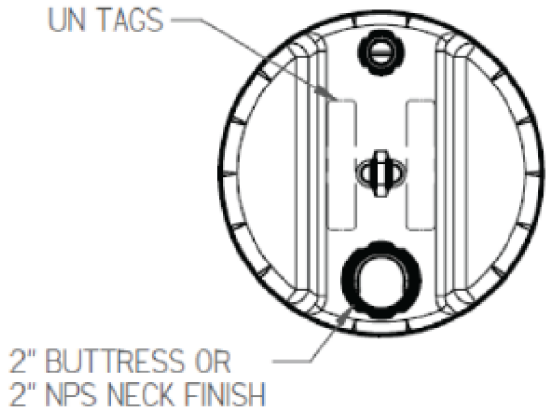

NOTES:
 AVAILABLE TO MEET UN IHI STANDARDS
WEIGHT:
 -3100 GRAMS NOMINAL
MATERIAL:
 -PREMIUM HDPE
 -MEETS FDA STANDARDS

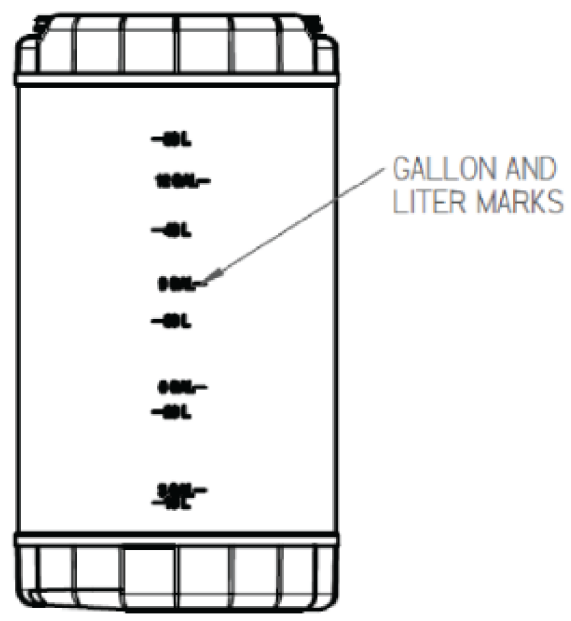
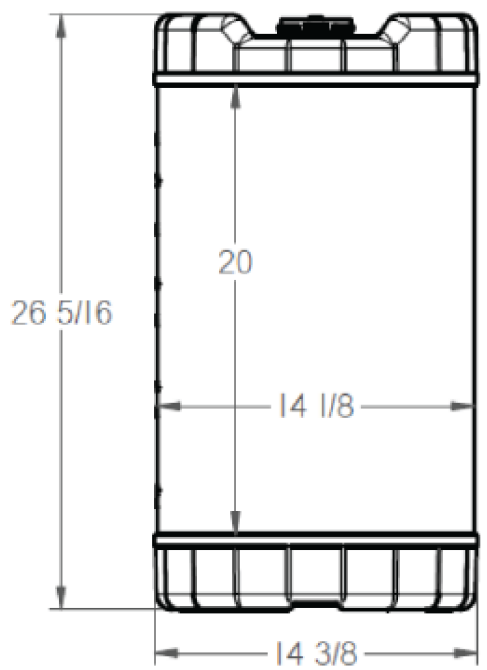

pipeline Packaging 30310 Emerald Valley Pkwy
 Glenwillow, OH 44139

PPC ITEM NUMBER: 80029 SKU: 03-14-079-00020
 DRAWN BY: - CHECKED BY: - DATE: 2/19/2019

DESCRIPTION: 15 Gal Tight Head Plastic Drum COLOR: Natural
 PART MATERIAL: - VOLUME: - WEIGHT: -
 DWG NO.: - DWG SIZE: A SHEET NO: 1 of 1 REV: -

PROPRIETARY AND CONFIDENTIAL
 THE INFORMATION CONTAINED IN THIS DRAWING IS THE SOLE PROPERTY OF PIPELINE PACKAGING. ANY REPRODUCTION IN PART OR AS A WHOLE WITHOUT THE WRITTEN PERMISSION OF PIPELINE PACKAGING IS PROHIBITED.

UNLESS OTHERWISE SPECIFIED:
 UNITS OF MEASURE: Inches
 TOLERANCES: Specified in drawing