

55 gal Open Head Black Steel Drum with 2" and 3/4" Fittings

NOTE: ALL FLANGES AND PLUGS DESCRIBED IN ISO STANDARDS
 NOTE: ALL DIMENSIONS ARE FOR REFERENCE USE ONLY

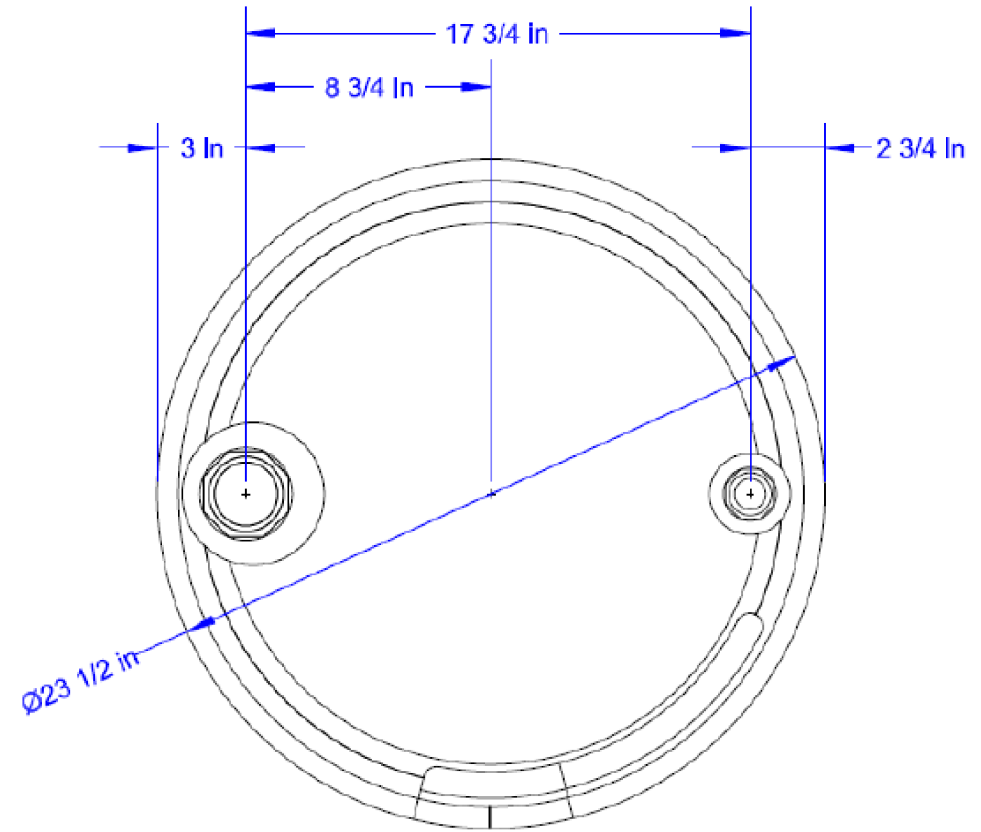
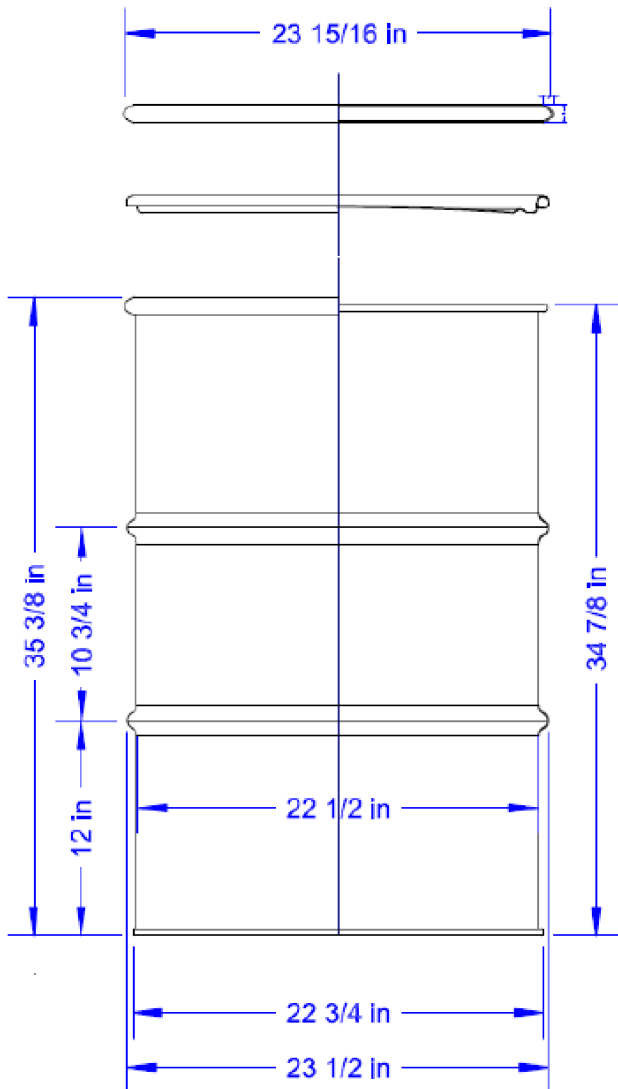

TOP VIEW

Pipeline Packaging 30310 Emerald Valley Pkwy
 Glenwillow, OH 44139

PPC ITEM NUMBER: 82148 SKU: 03-19-048-00107
 DRAWN BY: - CHECKED BY: - DATE: 3/12/2019

DESCRIPTION: 55 Gal Open Head Steel Drum COLOR: Black

PART MATERIAL: - VOLUME: - WEIGHT: -

DWG NO.: - DWG SIZE: A SHEET NO: 1 of 1 REV: -

PROPRIETARY AND CONFIDENTIAL

THE INFORMATION CONTAINED IN THIS DRAWING IS THE SOLE PROPERTY OF PIPELINE PACKAGING. ANY REPRODUCTION IN PART OR AS A WHOLE WITHOUT THE WRITTEN PERMISSION OF PIPELINE PACKAGING IS PROHIBITED.

UNLESS OTHERWISE SPECIFIED:

UNITS OF MEASURE: Inches
 TOLERANCES: Specified in drawing