

55 gal Open Head Black Steel Drum

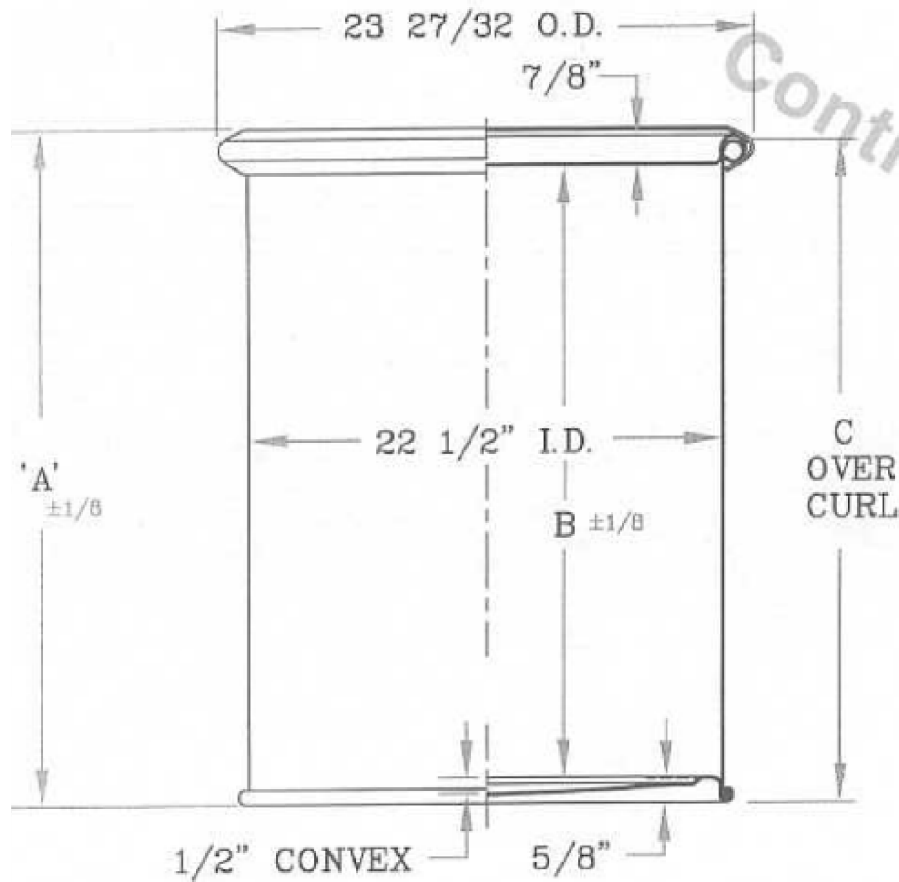

NOTE:

(#) WEIGHTS WITH 16 GA. BOLTED LOCKUNG RING. ADD 1.1 LBS FOR LEVER LOCK 16 GA. ADD 1.5 LBS FOR DRUMS WITH 12 GA. BOLT LOCKING RINGS

(*) INSERT 'B' FOR LEVER LOCK RING OR 'D' FOR BOLTED RING

WEIGHTS INCLUDE .6 LBS. AVG. FOR 3/4" AND 2" OPENINGS

SPECIFY OPENINGS BY CODE LETTER PER. DWG. DA-98

ASSEMBLY CODE NUMBER	ACT. CAP. GAL.	DIMENSIONS		
		A	B	C
55GAL C32	57.7	35 1/4	33 1/2	34 15/16
57GAL C32	59.3	36 1/16	34 5/16	35 3/4



30310 Emerald Valley Pkwy
Glenwillow, OH 44139

PPC ITEM NUMBER: 82114 SKU: 03-19-048-00130
DRAWN BY: - CHECKED BY: - DATE: 3/12/2019

DESCRIPTION: 55 Gal Open Head Steel Drum COLOR: Black
PART MATERIAL: - VOLUME: - WEIGHT: -
DWG NO.: - DWG SIZE: A SHEET NO: 1 of 1 REV: -

PROPRIETARY AND CONFIDENTIAL
THE INFORMATION CONTAINED IN THIS DRAWING IS THE SOLE PROPERTY OF PIPELINE PACKAGING. ANY REPRODUCTION IN PART OR AS A WHOLE WITHOUT THE WRITTEN PERMISSION OF PIPELINE PACKAGING IS PROHIBITED.

UNLESS OTHERWISE SPECIFIED:
UNITS OF MEASURE: Inches
TOLERANCES: Specified in drawing