

55 gal Tight Head Black Steel Drum with 2" and 3/4" EPDM Gasket Fittings

ASSEMBLY CODE NUMBER	ACT. CAP. GAL.	DIMENSIONS				
		A	B	C	D	E
55GAL C31	57.6	34 3/8	33 1/16	11 11/16	23 19/32	1/2
56GAL C31	58.4	34 13/16	33 1/2	11 15/16	23 19/32	1/2
57GAL C31	59.3	35 5/16	34	12 3/16	23 19/32	1/2
209LTR C31	219L	34 5/8	33 5/16	11 13/16	23 19/32	1/2
210LTR C31	220L	34 3/4	33 7/16	11 7/8	23 19/32	1/2
57.5GAL C31	60.1	35 13/16	34 1/2	12 13/32	23 19/32	1/2

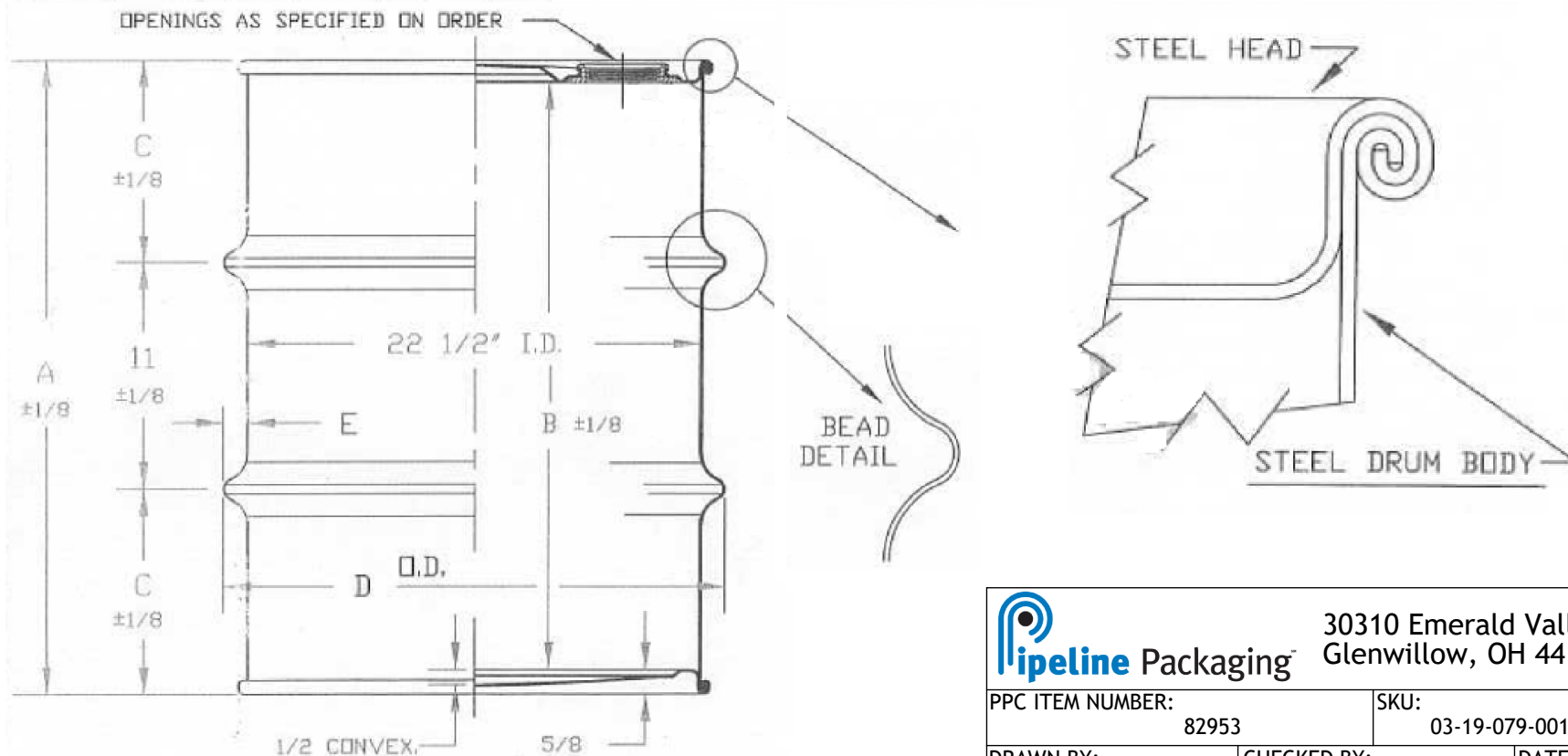

Pipeline Packaging 30310 Emerald Valley Pkwy
Glenwillow, OH 44139

PPC ITEM NUMBER: 82953 SKU: 03-19-079-00141

DRAWN BY: - CHECKED BY: - DATE: 3/12/2019

DESCRIPTION: 55 Gal Tight Head Steel Drum COLOR: Black

PART MATERIAL: - VOLUME: - WEIGHT: -

DWG NO.: - DWG SIZE: A SHEET NO: 1 of 1 REV: -

PROPRIETARY AND CONFIDENTIAL
THE INFORMATION CONTAINED IN THIS DRAWING IS THE SOLE PROPERTY OF PIPELINE PACKAGING. ANY REPRODUCTION IN PART OR AS A WHOLE WITHOUT THE WRITTEN PERMISSION OF PIPELINE PACKAGING IS PROHIBITED.

UNLESS OTHERWISE SPECIFIED:
UNITS OF MEASURE: Inches
TOLERANCES: Specified in drawing