

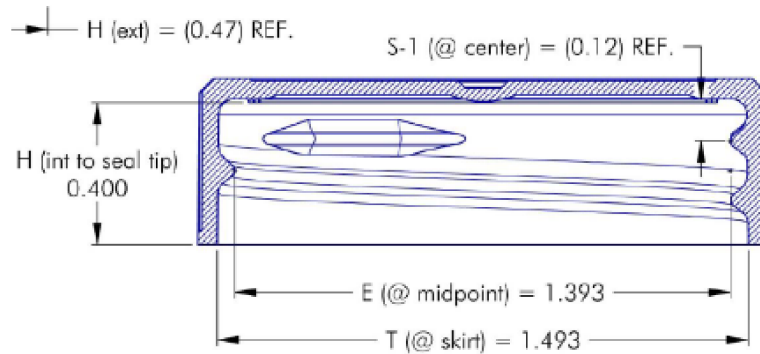

NOTES: (UNLESS OTHERWISE SPECIFIED)
 1. ALL DIMENSIONS ARE IN INCHES.
 2. TOLERANCE ON ALL DIMENSIONS IS ± 0.010 " EXCEPT WHERE NOTES AS "REF.".



		30310 Emerald Valley Pkwy Glenwillow, OH 44139	
		PPC ITEM NUMBER: 71476	SKU: 05-16-019-00216
DRAWN BY: -	CHECKED BY: -	DATE: 2/14/2019	
DESCRIPTION: 38-400 Cont. Thread PP Closure		COLOR: -	
PART MATERIAL: -	VOLUME: -	WEIGHT: -	
DWG NO.: -	DWG SIZE: A	SHEET NO: 1 of 2	REV: -

PROPRIETARY AND CONFIDENTIAL

THE INFORMATION CONTAINED IN THIS DRAWING IS THE SOLE PROPERTY OF PIPELINE PACKAGING. ANY REPRODUCTION IN PART OR AS A WHOLE WITHOUT THE WRITTEN PERMISSION OF PIPELINE PACKAGING IS PROHIBITED.

UNLESS OTHERWISE SPECIFIED:

UNITS OF MEASURE: Inches

TOLERANCES: Specified in drawing

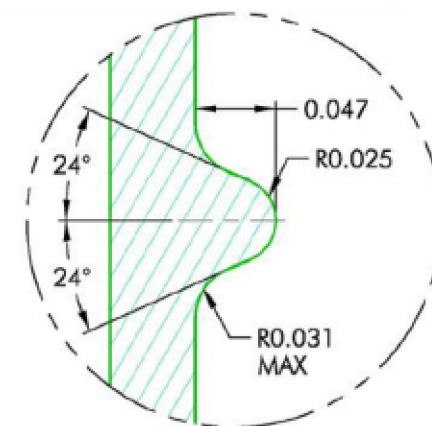
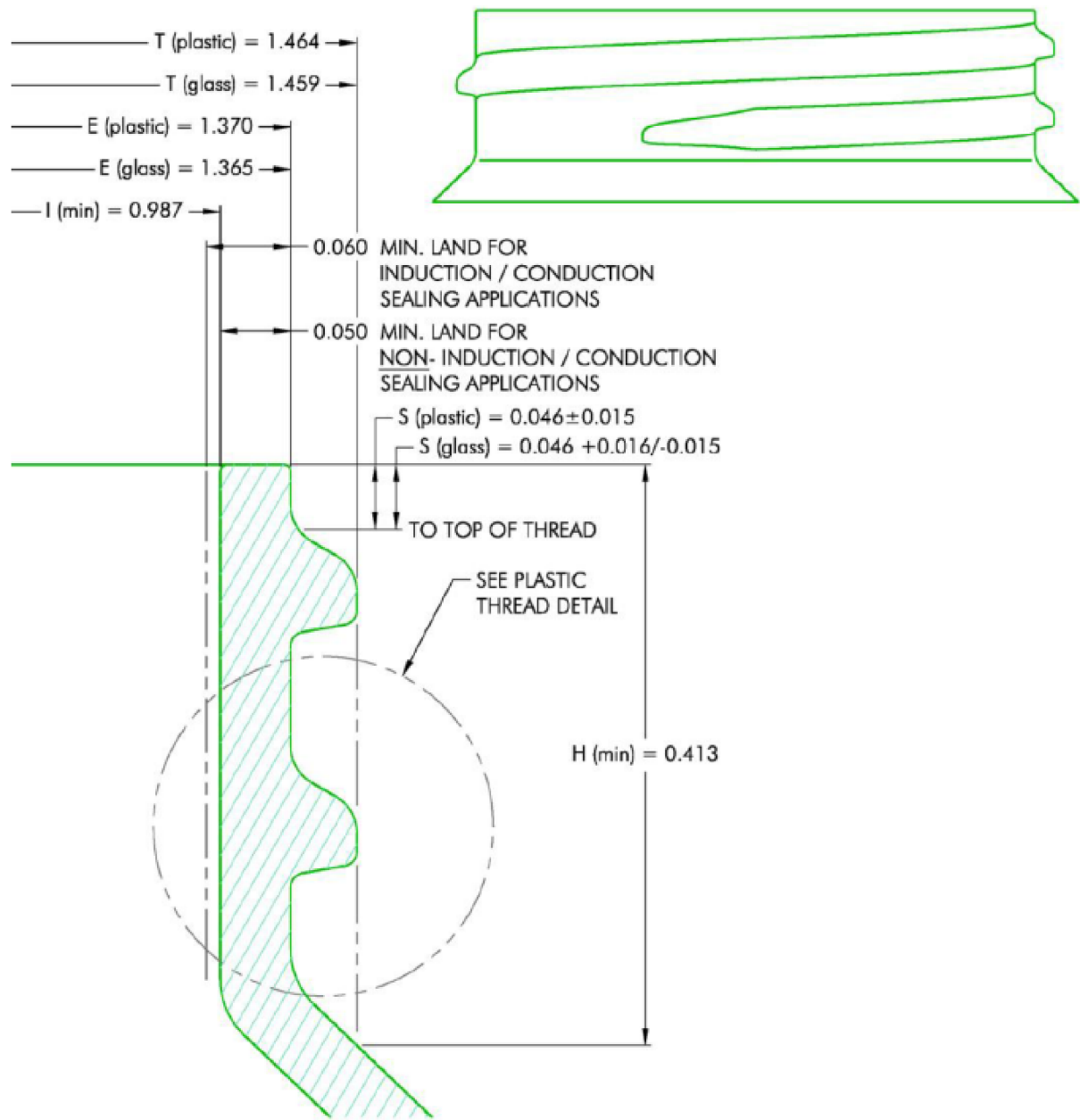

GLASS THREAD DETAIL
SCALE 10 : 1

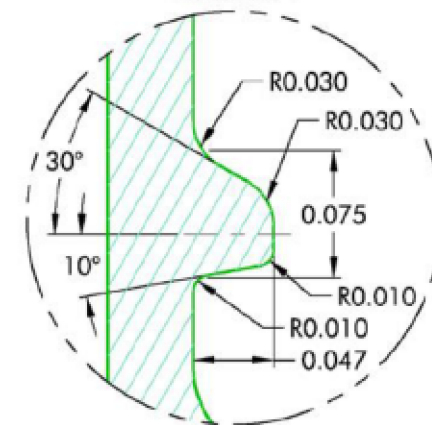

PLASTIC THREAD DETAIL
SCALE 10 : 1

MATERIAL	TOLERANCE
PP / PE	± 0.012
PET	± 0.006
GLASS	$+0.017 / -0.018$



Pipeline Packaging

30310 Emerald Valley Pkwy
Glenwillow, OH 44139

PPC ITEM NUMBER: 71476	SKU: 05-16-019-00216	
DRAWN BY:	CHECKED BY:	DATE: 2/14/2019

DESCRIPTION: 38-400 Cont. Thread PP Closure	COLOR: -		
PART MATERIAL: -	VOLUME: -	WEIGHT: -	
DWG NO.:	DWG SIZE: A	SHEET NO: 2 of 2	REV: -

PROPRIETARY AND CONFIDENTIAL

THE INFORMATION CONTAINED IN THIS DRAWING IS THE SOLE PROPERTY OF PIPELINE PACKAGING. ANY REPRODUCTION IN PART OR AS A WHOLE WITHOUT THE WRITTEN PERMISSION OF PIPELINE PACKAGING IS PROHIBITED.

UNLESS OTHERWISE SPECIFIED:

UNITS OF MEASURE: Inches

TOLERANCES: Specified in drawing