

SECTION A-A

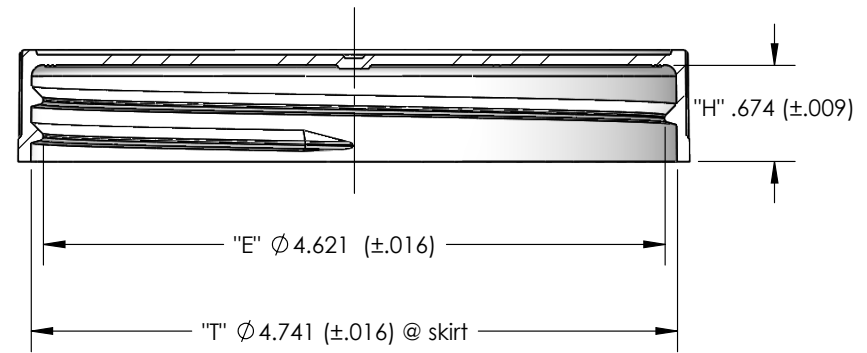

Ribbed Detail

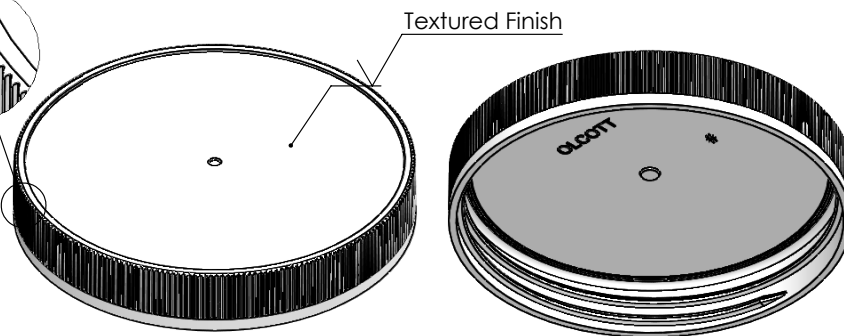

THREAD PITCH: 5 T.P.I.
 GATE LOCATION: EXTERIOR - TOP
 MATERIAL: POLYPROPYLENE

OF THREAD TURNS: 1-1/2 TURNS
 PART WEIGHT: 27.4 Grams (±5%)

DISCLAIMER

THIS INFORMATION IS PROVIDED AS A GENERAL GUIDE, INCLUDING DIMENSIONS. IT IS THE CUSTOMER'S RESPONSIBILITIES TO SELECT THE PROPER CONTAINER FOR PRODUCT AND APPLICATION COMPATIBILITY.

DISTRIBUTED BY:



REF NO.:

DWG30304

DESCRIPTION:

120 mm PP Foam Lined Screw Cap

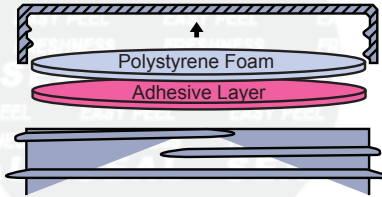
Product	PS-113 (Pressure Sensitive)		
Scope	One piece uniform polystyrene foam coated on one side with a specially formulated torque-activated adhesive. (Not approved for use with wet products.)		
Composition	Material	Standard	Metric
	Polystyrene Foam	0.020"	0.508 mm
	Adhesive Layer	0.002"	0.051 mm
			
FDA Status: 21 CFR 177.1210	Recommended Storage and Handling: Refer to website		
Drug Master File (DMF): 3948	EU / EP Reg.:		
GTR Oxygen: 2290 cc/m ² .Day (ASTM D3985)	MVTR: 5.85 g/m ² .Day (ASTM F1249)		
Print Location (if any):			

DISCLAIMER

THIS INFORMATION IS PROVIDED AS A GENERAL GUIDE, INCLUDING DIMENSIONS. IT IS THE CUSTOMER'S RESPONSIBILITIES TO SELECT THE PROPER CONTAINER FOR PRODUCT AND APPLICATION COMPATIBILITY.

DISTRIBUTED BY: 	REF NO.: DWG30304
DESCRIPTION: 120 mm PP Foam Lined Screw Cap	