

38mm SP400 NECK DETAIL 2X SCALE
 "M" STYLE THREAD
 ONE FULL TURN
 6 THREADS PER INCH

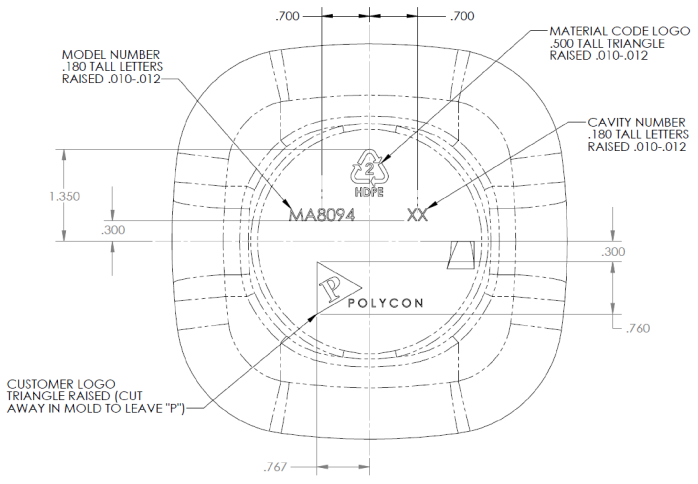
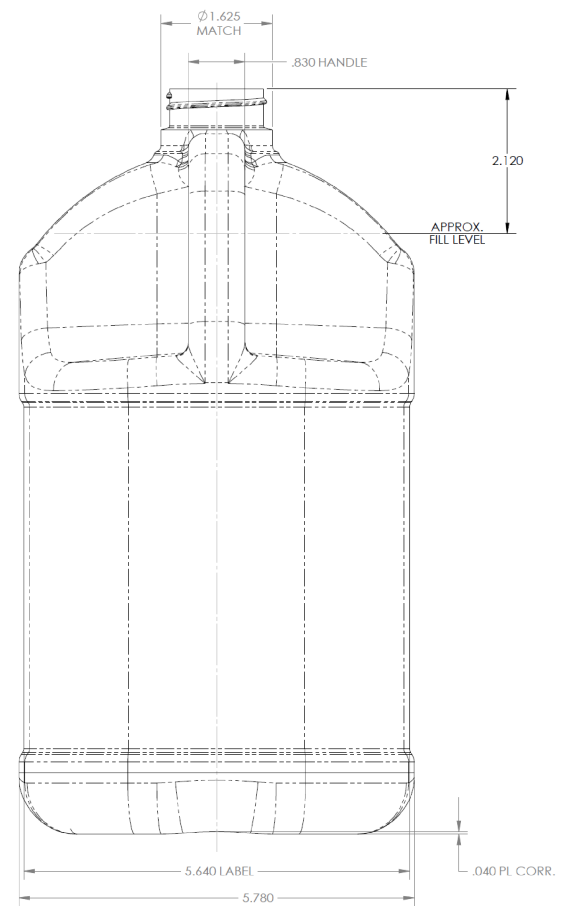
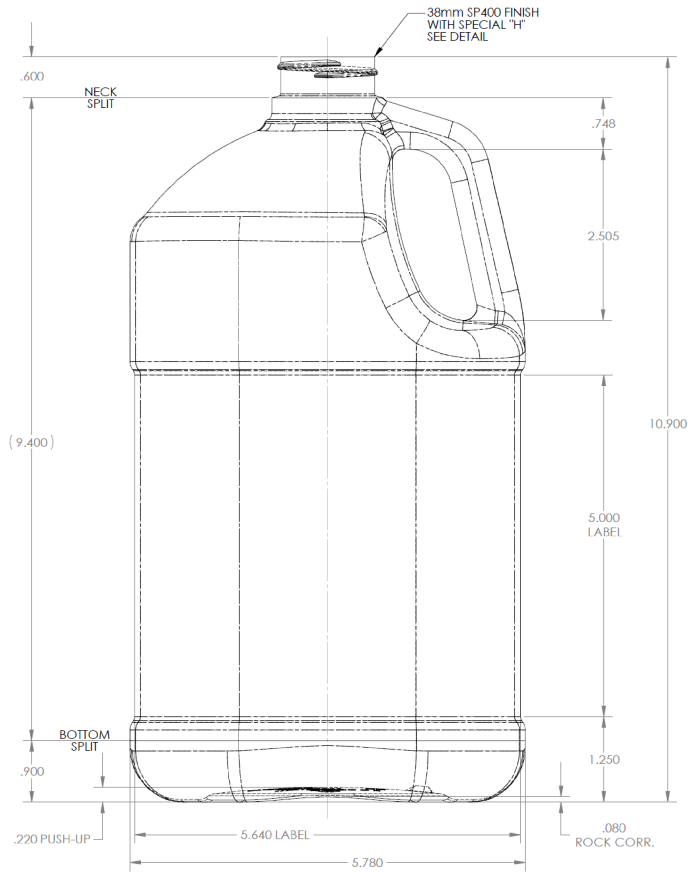

- NOTES**
1. WEIGHT - 117.5 ± 2.5 gms
 2. OVERFLOW CAPACITY - 134.5 oz
 3. AVERAGE WALL THICKNESS - .026"

DISCLAIMER

THIS INFORMATION IS PROVIDED AS A GENERAL GUIDE, INCLUDING DIMENSIONS. IT IS THE CUSTOMER'S RESPONSIBILITIES TO SELECT THE PROPER CONTAINER FOR PRODUCT AND APPLICATION COMPATIBILITY.

DISTRIBUTED BY: 	REF NO.:
	DWG10268
DESCRIPTION: 128 oz HDPE Industrial Square, 38-400	