

38MM CR SNAP-LOK F-STYLE (0038R176)

T=01.464±.012 [037.19±0.30]
 E=01.370±.012 [034.80±0.30]
 B=01.540±.015 [039.12±0.38]
 S1=0.143±.015 [3.63±0.38]
 S2=0.547±.015 [13.89±0.38]
 H=0.650±.015 [16.51±0.38]

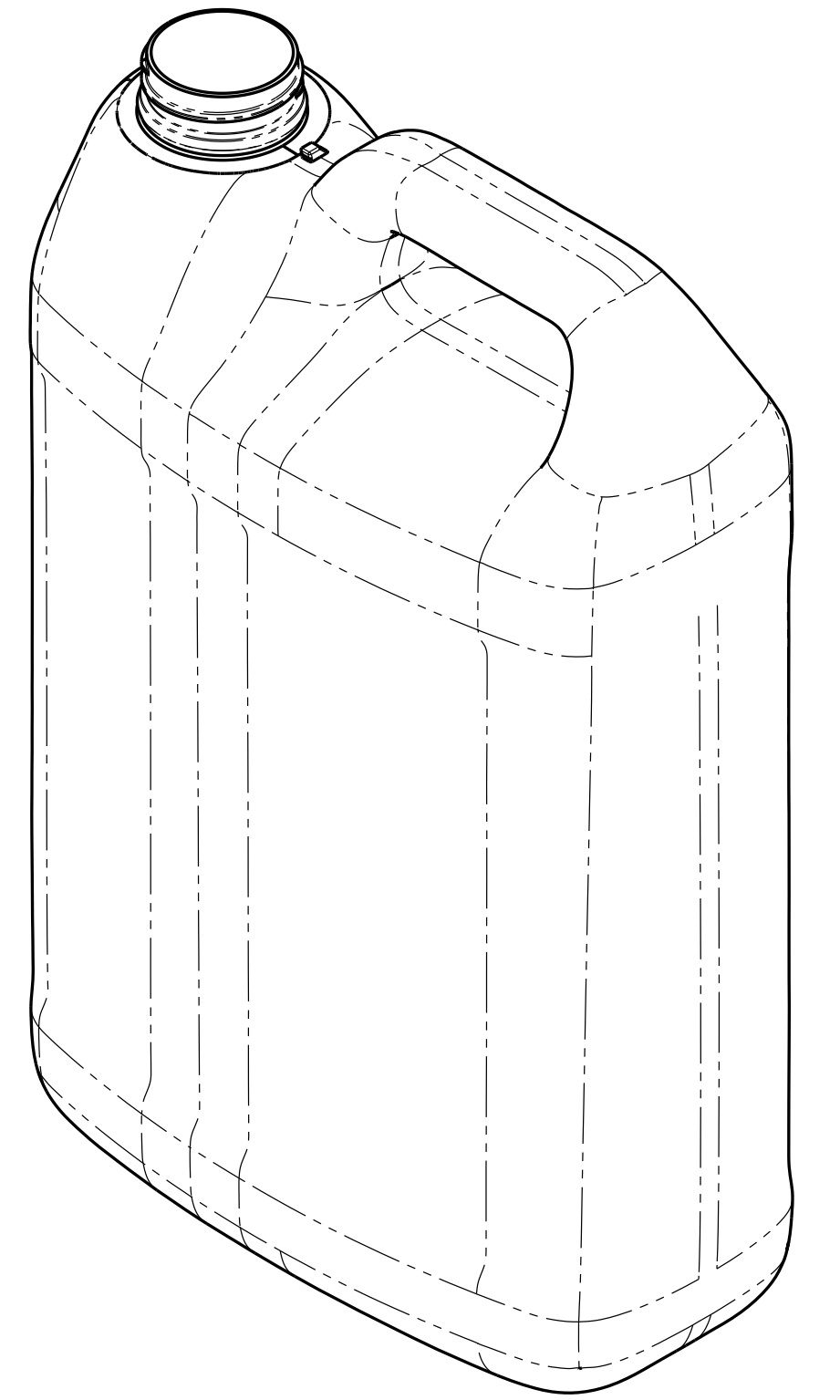

SCALE 2:1

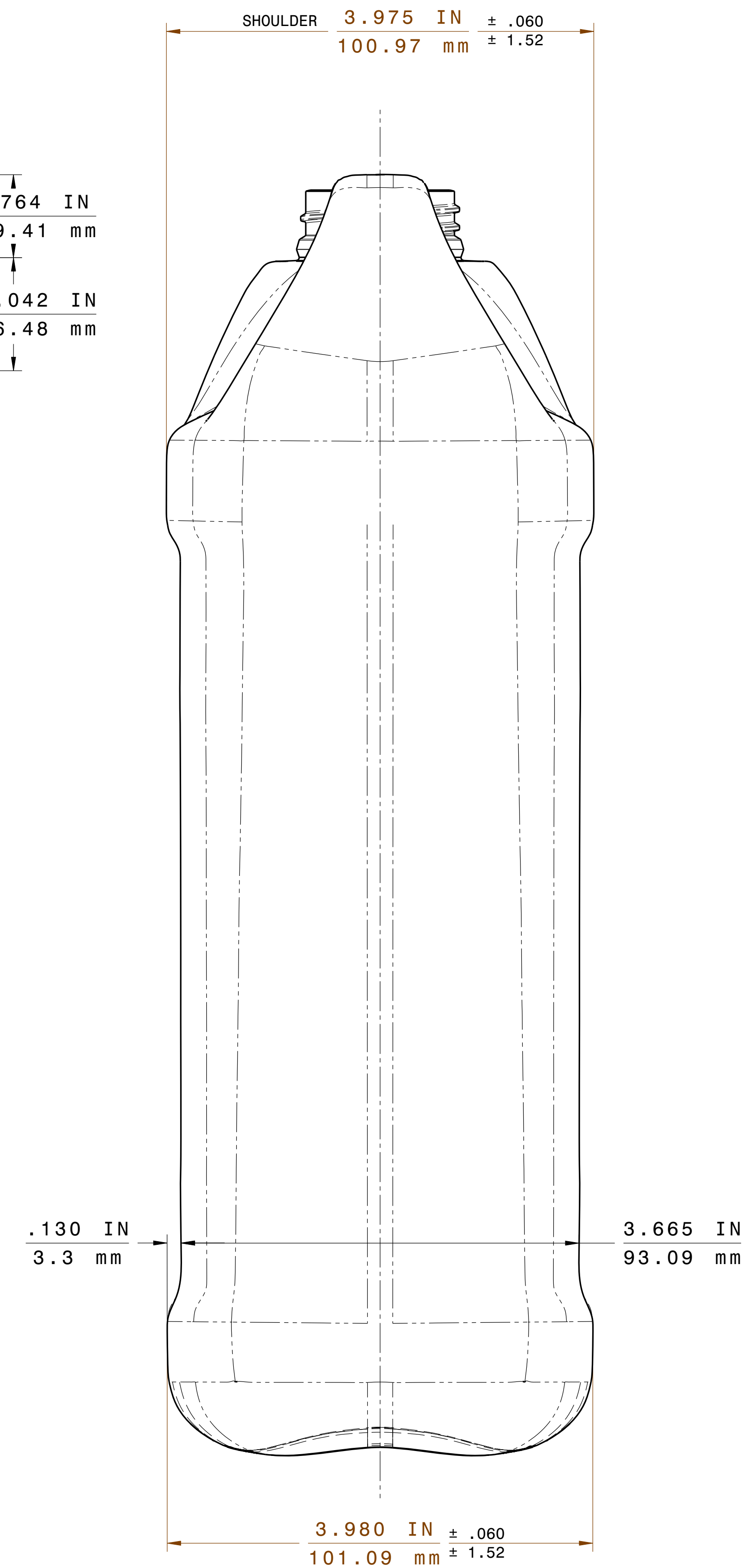
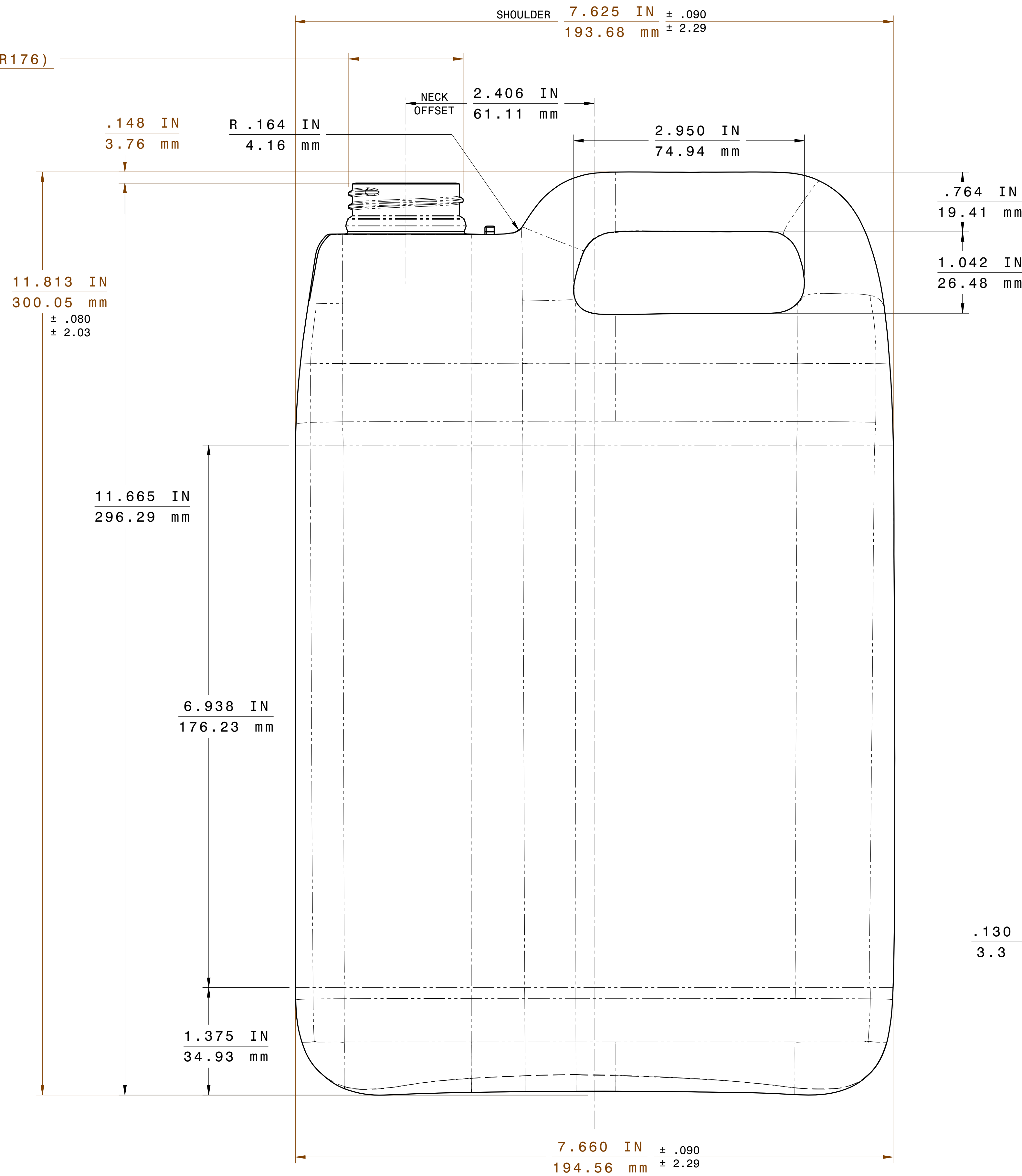
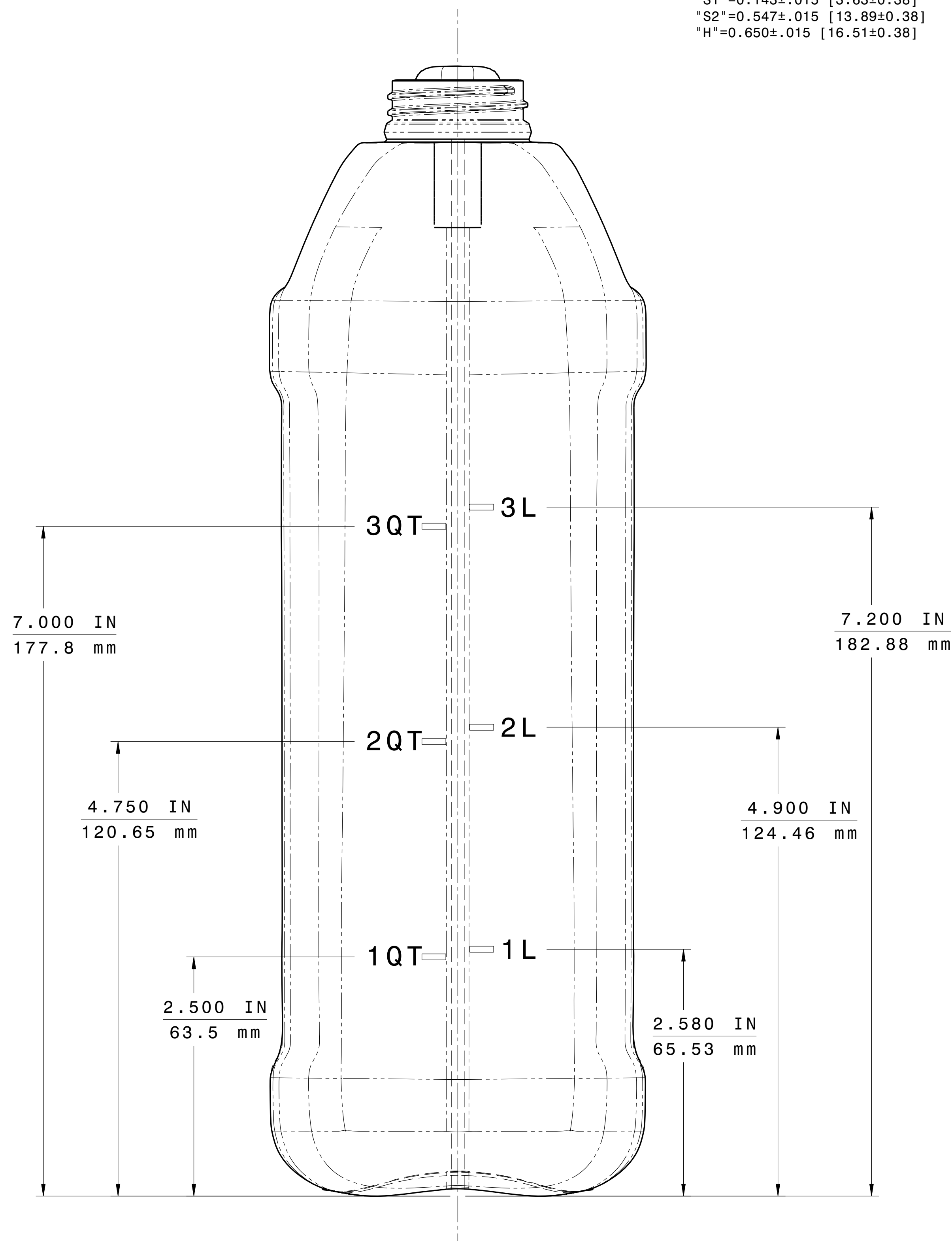
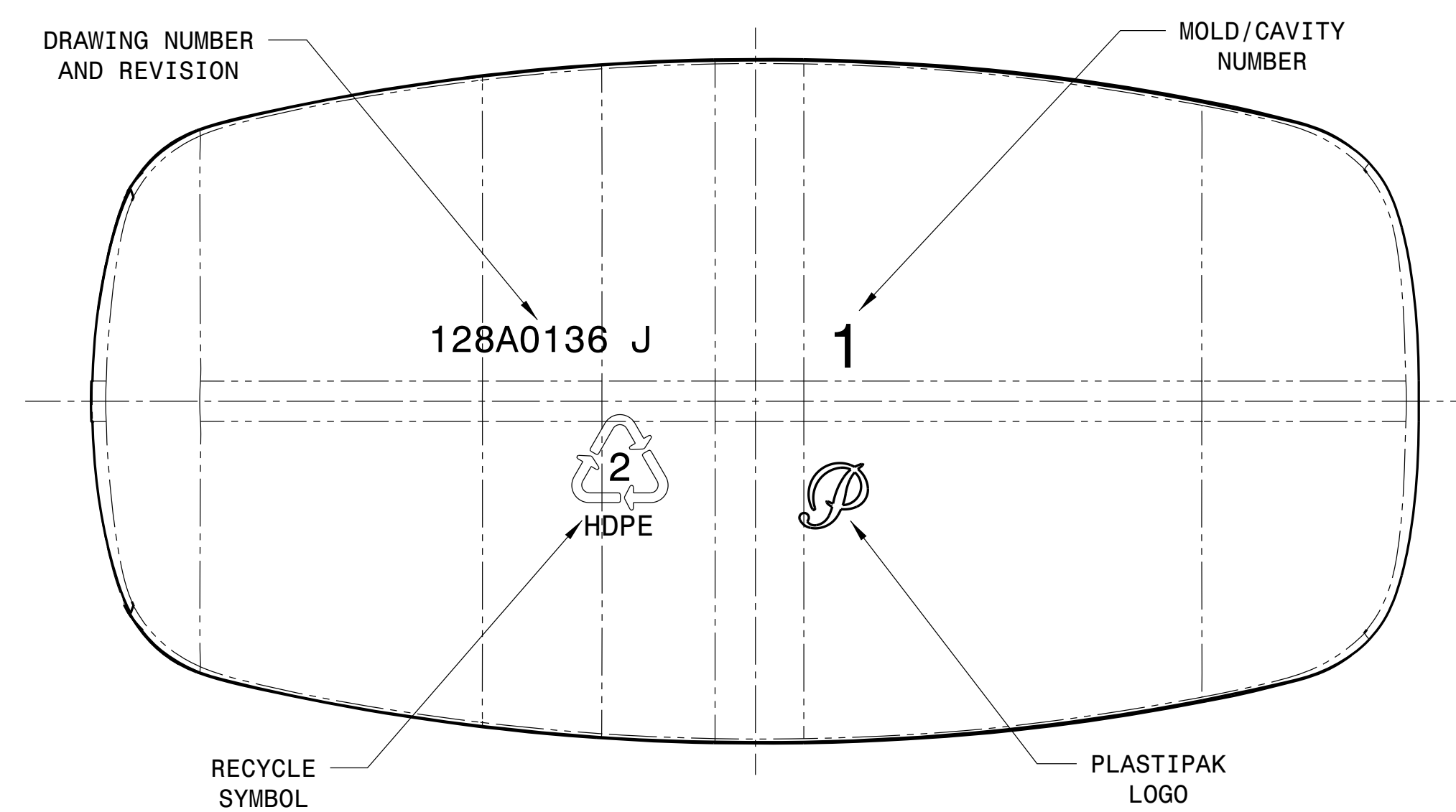

- GENERAL NOTES
- (1) MATERIAL: HDPE
 - (2) WEIGHT: 140 ± 5 GRAMS
145 ± 5 GRAMS
150 ± 5 GRAMS
155 ± 5 GRAMS
 - (3) CAPACITY: 128 FL OZ
OVERFLOW: 146.92 ± 2.16 FL OZ
[4345 ± 64 ML]
 - (4) REFERENCE DRAWINGS: 67D-128-033
67D-128A0108
 - (5) DRAWING FOR PAPER IML
REF LABEL DWG: 128A0277
 - (6) TARGET WEIGHT SPEC VARIED DEPENDING
ON CUSTOMER PREFERENCE

DISCLAIMER

THIS INFORMATION IS PROVIDED AS A GENERAL GUIDE, INCLUDING DIMENSIONS. IT IS THE CUSTOMER'S RESPONSIBILITIES TO SELECT THE PROPER CONTAINER FOR PRODUCT AND APPLICATION COMPATIBILITY.

DISTRIBUTED BY:



REF NO.:

DWG31190

DESCRIPTION:

128 oz White HDPE Plastic F Style Bottle, 38-400, 140 Gram, 25% PCR