

38mm SP-400 NECK FINISH
DETAIL 3:2X SCALE

- 1) "L" STYLE THREAD
- 2) 1.5 (540°) TURNS OF THREAD
- 3) SPECIAL "H"
- 4) PITCH = .167"

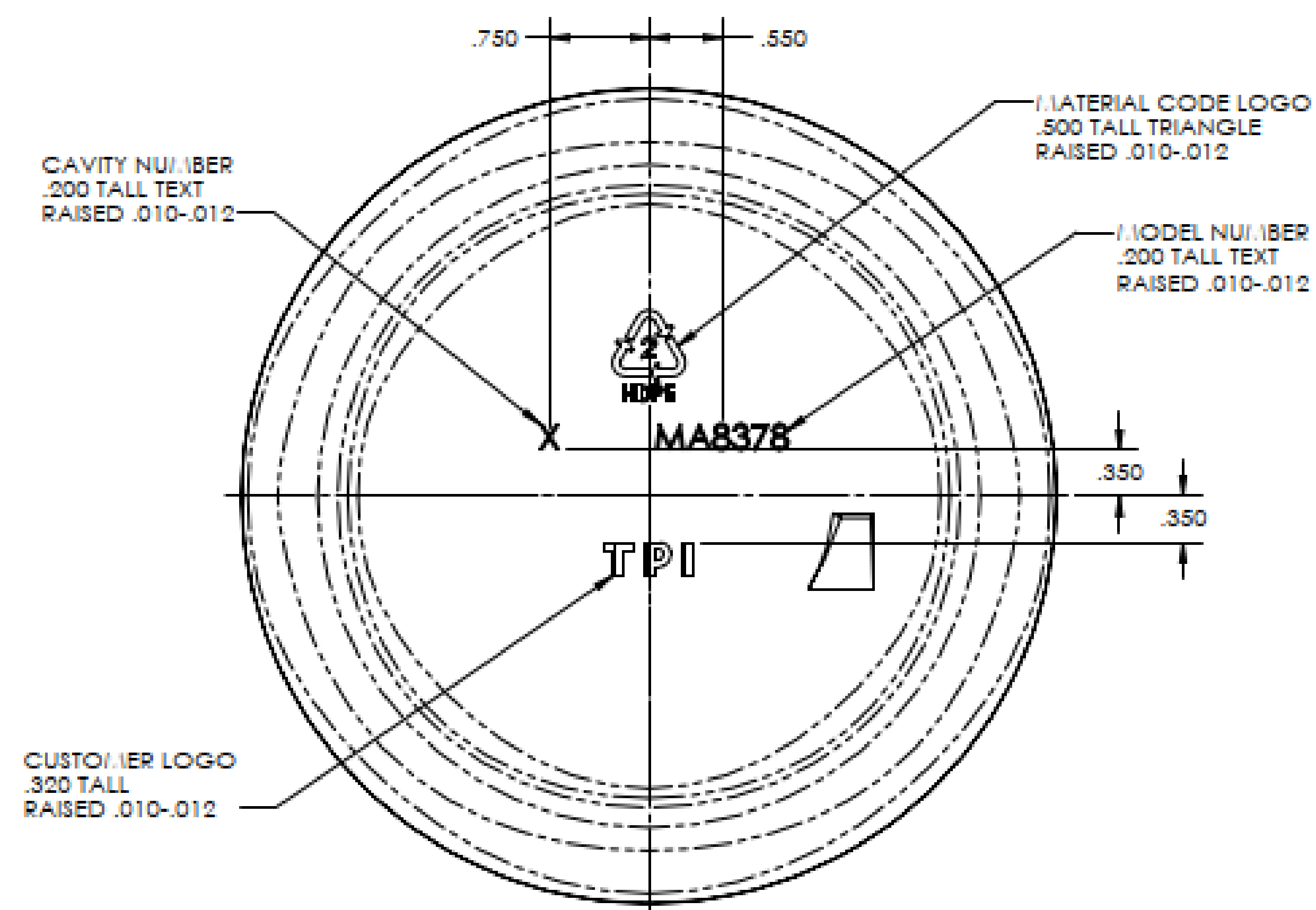
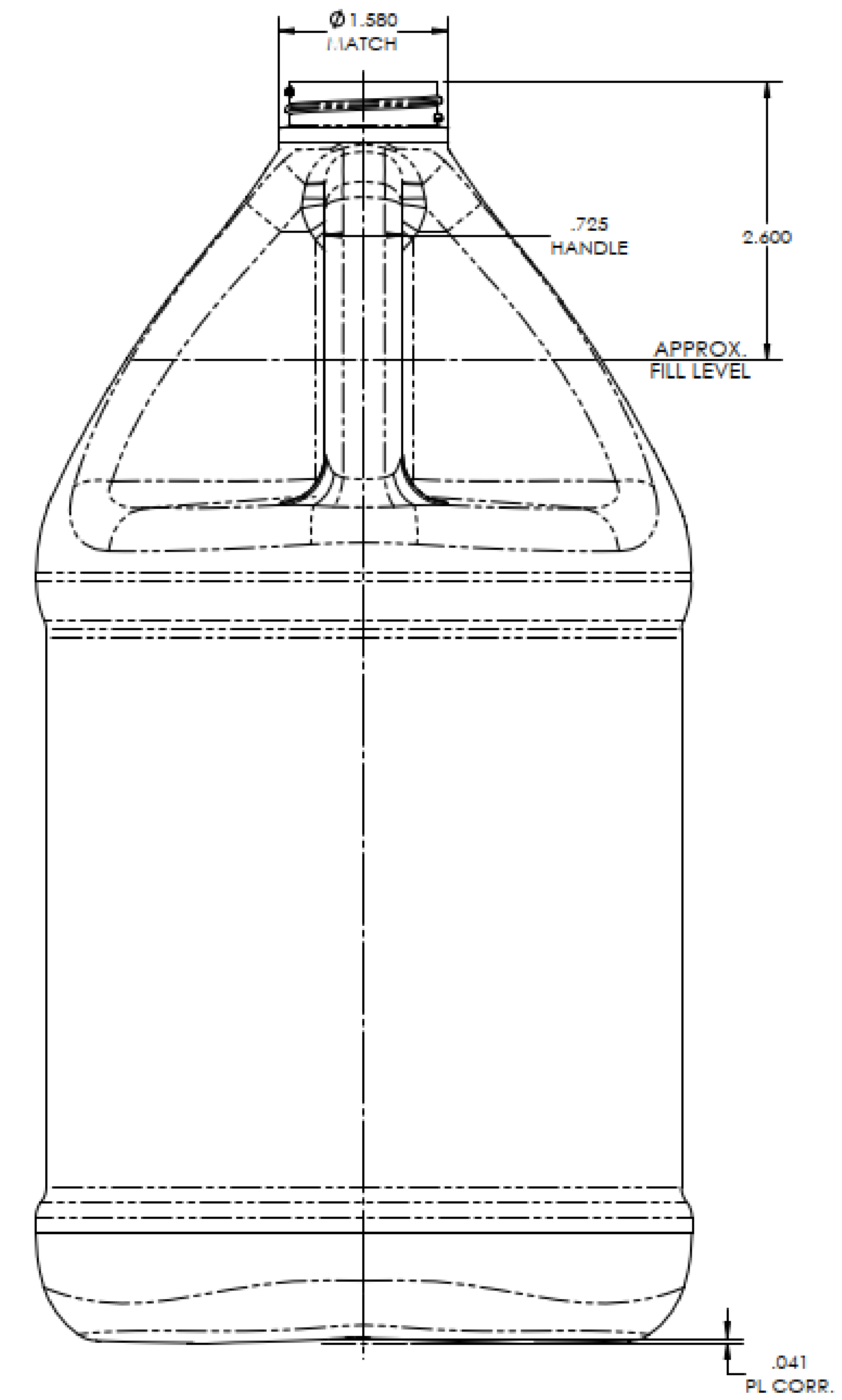
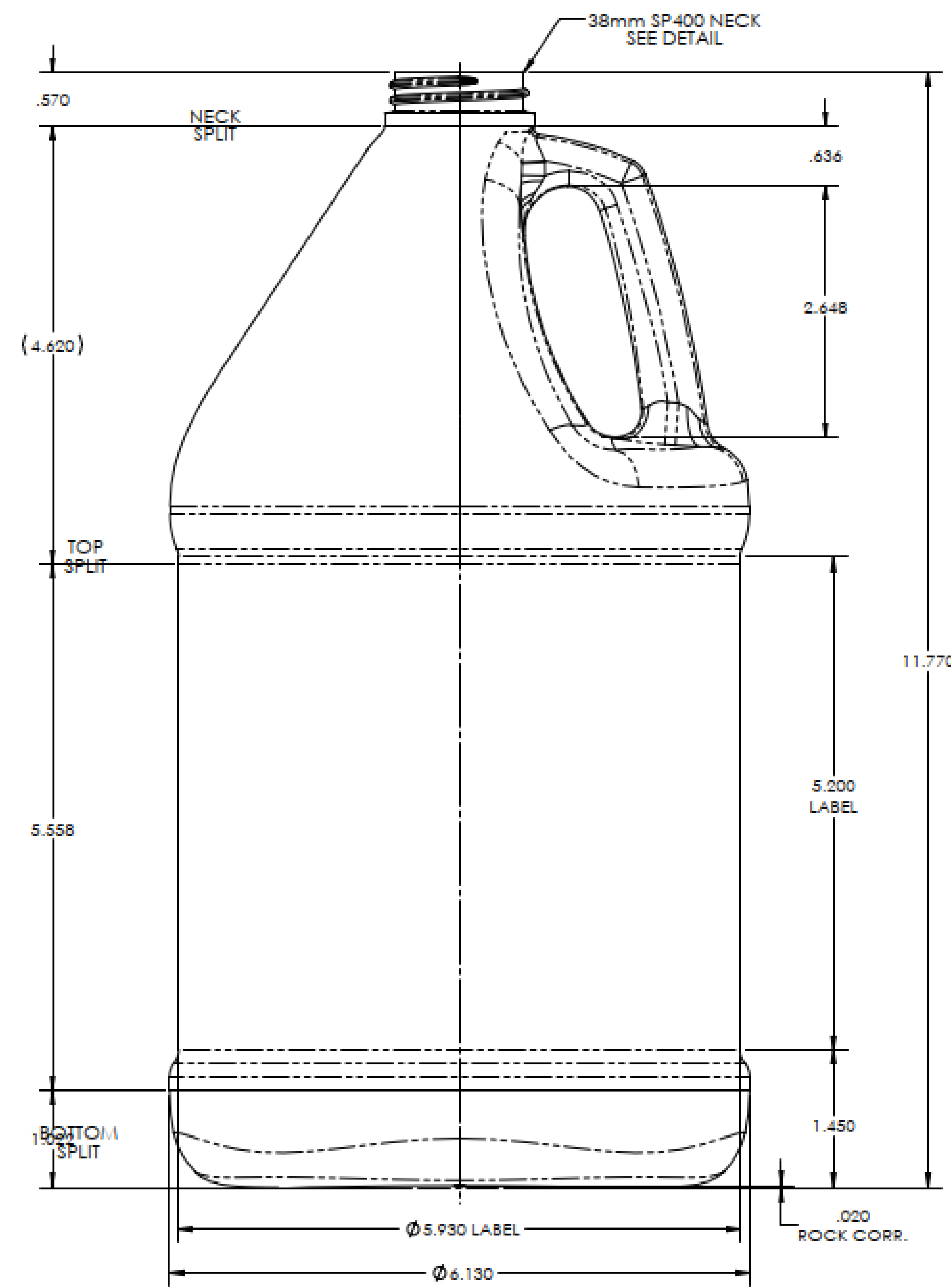

Container Data:	
Weight	See Note #2
Fill Level	128.0 oz.
Overflow	134.4 oz.
Material	HDPE

- Notes:
- 1) Tolerances Unless Specified:
Vertical -- $\pm .080$ "
Horizontal -- $\pm .090$ "
Volumetric -- ± 1.5 oz.
 - 2) Container Weight:
128oz. -- Normal Target 118 grams
(Used for Volume Calculations)
-- Range 100-150 grams_B

DISCLAIMER

THIS INFORMATION IS PROVIDED AS A GENERAL GUIDE, INCLUDING DIMENSIONS. IT IS THE CUSTOMER'S RESPONSIBILITIES TO SELECT THE PROPER CONTAINER FOR PRODUCT AND APPLICATION COMPATIBILITY.

DISTRIBUTED BY:



REF NO.:

DWG 31188

DESCRIPTION:

128 oz White HDPE Plastic Industrial Round Bottle, 38-400