

2-Gallon Round Container with Gasket EZ Cover®

Multiple Uses

Dry Products
Liquid Products

Product Codes

Container:
Description: 2-gallon round can

Cover:

Description: Tamper-evident, round EZ Cover® with tubular gasket and Ring Pull®

Features

Gauge: 65 mil.
Nominal capacity: 2.0 USG / 7.6 L
Stack performance: 200 lbs.*
Tare weights: Body: .80 lbs. / .36 kgs.
Cover: .30 lbs. / .14 kgs.

Note: *Ratings will be reduced with uneven load distribution.

Specifications with Cover

Dimensions: 9-15/16"D X 9-7/16"H
Maximum capacity: 2.1 USG / 7.9 L
Tare weight: 1.10 lbs. / .50 kgs.

Colors

Standard: White, Black and Natural
Custom: Available at manufacturer's discretion

Decorating Options

Silk - Screening: 25-1/2"W X 6"H
Four or six* color offset printing
Print area: 27-1/2"W X 6"H
NXT Graphics®

Note: *Where available

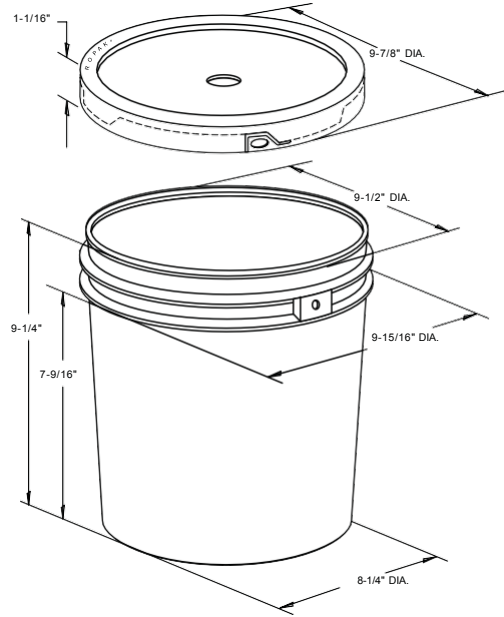

Shipping Data

	Bodies	Covers	Filled Containers
Qty. per pallet:	240	1,920 (24 boxes of 80)*	100 (20 per layer / 5 layers high)
Gross Weight: (lbs./kgs)**:	192/86.4	576/268.8	Pallet height: 51"
Den. (lbs./C.F./kgs./m3):	5.1/76.8	5.4/89.7	
Length (in./cm.):	49/124.5	48/121.9	
Width (in./cm.):	40/101.6	41/104.1	
Height (in./cm.):	33/83.8	93/236.2	

Estimated truckload quantity of 14,400 bodies and covers***

Notes: *Bulk pack also available
**Weight does not include pallet/packaging
***Truckload quantity based on 53' trailer

Materials

FDA approved materials
Resin: Body: High-Density Polyethylene (HDPE)
Cover: High-Density Polyethylene (HDPE)
Ethylene Propylene Diene Monomer (EPDM) Gasket
MSDS Sheets available upon request

Optional Carrying Handle

Revision 2/11-1

DISCLAIMER

THIS INFORMATION IS PROVIDED AS A GENERAL GUIDE, INCLUDING DIMENSIONS. IT IS THE CUSTOMER'S RESPONSIBILITIES TO SELECT THE PROPER CONTAINER FOR PRODUCT AND APPLICATION COMPATIBILITY.

DISTRIBUTED BY:



REF NO.:

DWG30200

DESCRIPTION:

2 Gallon Black HDPE OH Pail with handle