

2 Gallon Round Container

Features

- Reinforcing ribs to maintain container shape
- Tapered design allows for container nesting
- Hot fill capability up to 190°F with appropriate materials and freezer compatible
- Heat transfer decoration and 6 color offset print capability
- Accepts plastic or metal handles

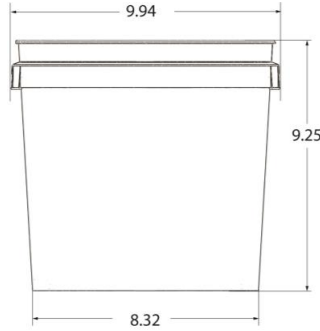

PRODUCT CODE.....2S TH2G65 (W) (B) (BU)

COMPATIBLE LID..... 2LSTT LH2GGTS

SPECIFICATIONS

Height.....9.25"
 Outer Diameter.....9.94"
 Thickness......65mil
 Print Area......26" x 5.5"
 Resin.....HDPE

VOLUME

Practical Fill.....2.0 gal. / 7.57 liters
 Overflow.....2.3 gal. / 8.70 liters

PACKAGING

Pack Count.....360
 Pack Dimensions..... 51.64" x 40.82" x 39.16"
 Cubic Feet......47.7
 Packs per Pallet.....2

ORDER QUANTITIES (53' Truckload)

2S & 2LSTT..... 14,400 bases & lids

DISCLAIMER

THIS INFORMATION IS PROVIDED AS A GENERAL GUIDE, INCLUDING DIMENSIONS. IT IS THE CUSTOMER'S RESPONSIBILITIES TO SELECT THE PROPER CONTAINER FOR PRODUCT AND APPLICATION COMPATIBILITY.

DISTRIBUTED BY:



REF NO.:

DWG30328

DESCRIPTION:

2 Gallon HDPE OH Pail