

## Multiple Uses

Dry Products  
Liquid Products

## Features

Gauge: 65 mil.  
Nominal capacity: 2.0 USG / 7.6 L  
Stack performance: 200 lbs.\*  
Tare weights: Body: .80 lbs. / .36 kgs.  
Cover: .30 lbs. / .14 kgs.

Note: \*Ratings will be reduced with uneven load distribution.

## Specifications with Cover

Dimensions: 9-15/16"D X 9-7/16"H  
Maximum capacity: 2.1 USG / 7.9 L  
Tare weight: 1.10 lbs. / .50 kgs.

## Colors

Standard: White, Black and Natural  
Custom: Available at manufacturer's discretion

## Decorating Options

Silk - Screening: 25-1/2"W X 6"H  
Four or six\* color offset printing  
Print area: 27-1/2"W X 6"H  
NXT Graphics®

Note: \*Where available

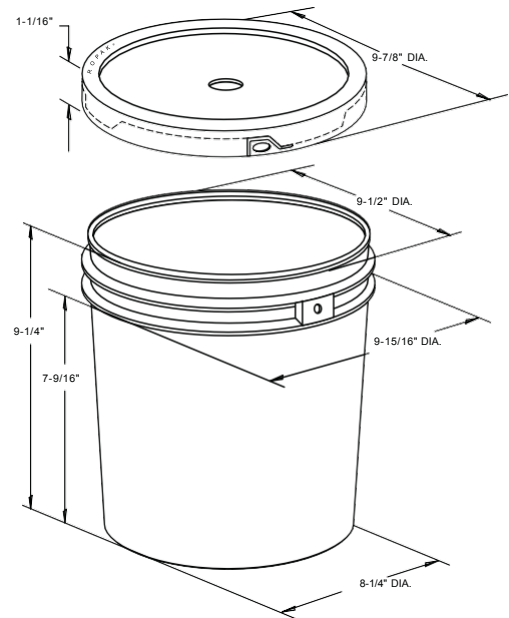

## Shipping Data

	<b>Bodies</b>	<b>Covers</b>
Qty. per pallet:	240	1,920 (24 boxes of 80)*
Gross Weight: (lbs./kgs)**:	192/86.4	576/268.8
Den. (lbs./C.F./kgs./m3):	5.1/76.8	5.4/89.7
Length (in./cm.):	49/124.5	48/121.9
Width (in./cm.):	40/101.6	41/104.1
Height (in./cm.):	33/83.8	93/236.2

Estimated truckload quantity of 14,400 bodies and covers\*\*\*

## Filled Containers

100 (20 per layer / 5 layers high)  
Pallet height: 51"

Notes: \*Bulk pack also available  
\*\*Weight does not include pallet/packaging  
\*\*\*Truckload quantity based on 53' trailer

## Materials

FDA approved materials  
Resin: Body: High-Density Polyethylene (HDPE)  
Cover: High-Density Polyethylene (HDPE)  
Ethylene Propylene Diene Monomer (EPDM) Gasket  
MSDS Sheets available upon request

## Optional Carrying Handle

### DISCLAIMER

THIS INFORMATION IS PROVIDED AS A GENERAL GUIDE, INCLUDING DIMENSIONS. IT IS THE CUSTOMER'S RESPONSIBILITIES TO SELECT THE PROPER CONTAINER FOR PRODUCT AND APPLICATION COMPATIBILITY.

DISTRIBUTED BY:



REF NO.:

DWG30329

DESCRIPTION:

2 Gallon HDPE OH Pail