

# 20.0 Liter Rectangular Tight Head with Swing Handle

## Product Uses

Liquid Products

## Product Codes

Container: **RTH Series**

Description: 20L Rectangular Tighthead

## Features

UN Rating: 3H1/Y1.8/100

Nominal capacity: 5.3 USG / 20.0L

Maximum capacity: 5.8 USG / 22.0 L

Tare weights: 2.74 lbs / 1.24 kgs

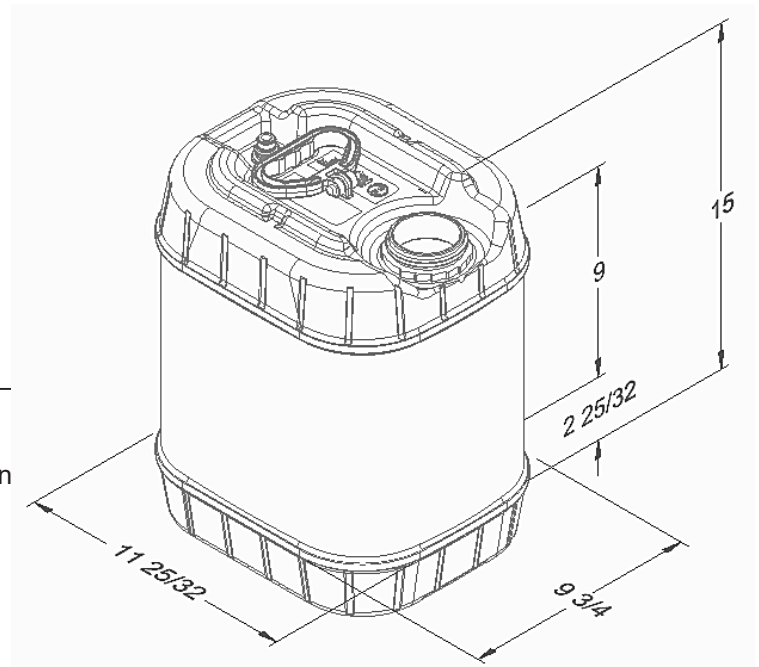

## Colors

Standard: White, Black, Blue and Natural

Custom: Available at manufacturer's discretion

## Decorating Options

Maximum Label Area:

Perimeter: 38-1/4" x 8-3/4" H

See Salesperson for Options

## Shipping Data

Qty. per floor spot:

112

Gross Weight (lbs./kgs)\*:

268 / 121

Length (in./cm.):

48 / 122

Width (in./cm.):

35.3 / 90

Height (in./cm.):

108.5 / 275.6

## Containers

Estimated truckload quantity of 3,360 containers\*\*

Notes: \*Weight does not include pallet / packaging

\*\*Truckload quantity based on 53' trailer

## Materials

FDA approved materials

Resin: Body: High-Density Polyethylene (HDPE)

Handle/Pin: High-Density Polyethylene (HDPE)

## Optional Carrying Handle

Swing Handle with Pin

DISTRIBUTED BY:



REF NO.:

DWG31106

DESCRIPTION:

20 Liter Dark Blue HDPE Plastic Square Tight Head Pail, 70 mm, 6 TPI

## DISCLAIMER

THIS INFORMATION IS PROVIDED AS A GENERAL GUIDE, INCLUDING DIMENSIONS. IT IS THE CUSTOMER'S RESPONSIBILITIES TO SELECT THE PROPER CONTAINER FOR PRODUCT AND APPLICATION COMPATIBILITY.