

Product Uses

Liquid Products

Product Codes

Container: **RTH Series (HO)**

Description: 20L Rectangular Tighthead

Features

UN Rating: 3H1/Y1.8/100
Nominal capacity: 5.3 USG / 20.0L
Maximum capacity: 5.6 USG / 21.0 L
Tare weights: 2.68 lbs / 1.215 kgs

Colors

Standard: White, Black, Blue and Natural
Custom: Available at manufacturer's discretion

Decorating Options

Maximum Label Area:
Perimeter: 38-1/4" x 8-3/4" H
See Salesperson for Options

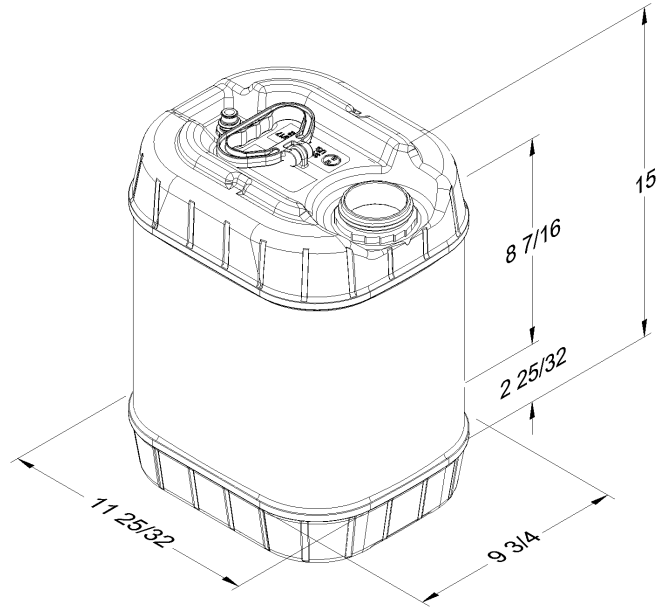

Shipping Data

Qty. per floor spot: 112
Gross Weight (lbs./kgs)*: 268 / 121
Length (in./cm.): 48 / 122
Width (in./cm.): 35.3 / 90
Height (in./cm.): 107.7 / 273.6

Containers

Filled Containers

Refer to BWAY document # ETS-CD-1002 for storage and shipping recommendations.

Estimated truckload quantity of 3,360 containers**

Notes: *Weight does not include pallet / packaging
**Truckload quantity based on 53' trailer

Materials

FDA approved materials
Resin: Body: High-Density Polyethylene (HDPE)
Handle/Pin: High-Density Polyethylene (HDPE)

Optional Carrying Handle

Swing Handle with Pin

DISTRIBUTED BY:



REF NO.:

DWG30341

DESCRIPTION:

20 Liter HDPE Square TH with Swing Handle

DISCLAIMER

THIS INFORMATION IS PROVIDED AS A GENERAL GUIDE, INCLUDING DIMENSIONS. IT IS THE CUSTOMER'S RESPONSIBILITIES TO SELECT THE PROPER CONTAINER FOR PRODUCT AND APPLICATION COMPATIBILITY.