

Multiple Uses

Dry Products
Liquid Products

Product Codes

Container: **5500 Series**
Description: 20 Liter LBR Standard Pail

Cover: **6500 Series**

Description: Standard Tear Skirt Cover
Note: *Multiple fitting and venting options available

Features

Gauge: 90 mil.
Nominal capacity: 5.3 USG / 20 L
Stack performance: 350 lbs.*
Tare weights: Body: 2.17 lbs. / .985 kgs
Cover: .66 lbs. / .300 kgs.
Note: *Ratings will be reduced with uneven load distribution.

Specifications with Cover

Dimensions: 12-3/8" D X 15-11/16"H
Maximum capacity: 5.36 USG / 20.3 L
Tare weight: 2.83 lbs. / 1.28 kgs.

Colors

Standard: White, Black and Natural
Custom: Available at manufacturer's discretion

Decorating Options

Four color offset printing
Print area: 33"W x 8-3/4"H
Sleeve or pressure sensitive labeling

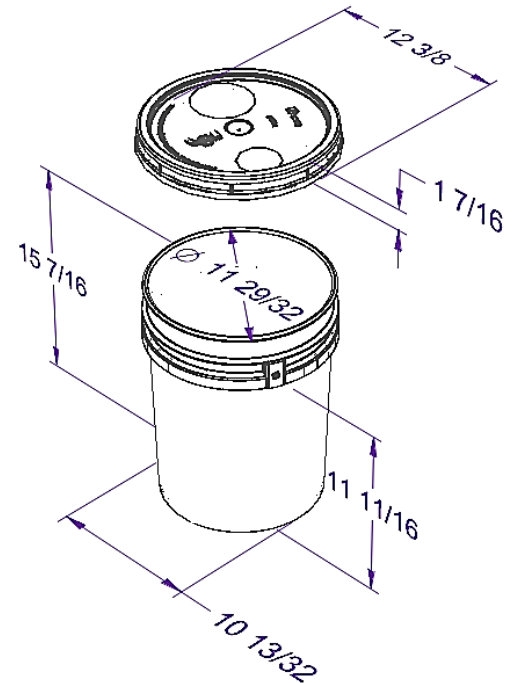

Shipping Data

Qty. per pallet/carton:
Gross Weight (lbs/kgs.)**:
Length (in./cm.):
Width (in./cm.):
Height (in./cm.):

Bodies

240*
520 / 236
50 / 127
38.5 / 98
51 / 129

Covers

1,200*
792 / 359
48 / 122
40 / 102
98 / 249

Filled Containers

36 (12 per layer / 3 layers high)
Pallet Height: 50.3"

Estimated truckload quantity of 5,520 bodies and covers***

Notes: *Quantity can vary based on customer request
**Weight does not include pallet/packaging
***Truckload quantity based on 53' trailer

Materials

FDA approved materials
Resin: Body: High-Density Polyethylene (HDPE)
Cover: High-Density Polyethylene (HDPE)

MSDS Sheets available upon request

Optional Carrying Handle

Wire or Plastic

DISTRIBUTED BY:



REF NO.:

DWG30342

DESCRIPTION:

20 Liter HDPE OH Pail

DISCLAIMER

THIS INFORMATION IS PROVIDED AS A GENERAL GUIDE, INCLUDING DIMENSIONS. IT IS THE CUSTOMER'S RESPONSIBILITIES TO SELECT THE PROPER CONTAINER FOR PRODUCT AND APPLICATION COMPATIBILITY.