

Rated Capacity	275 Gallons
Specific Gravity Maximum Rating	1.9 SG
Maximum Fill Temperature	150° F
Hydrostatic Pressure Rating	100 kPa in Cage
Inner Receptacle	<p>Blowmolded: HMWHDPE Resin: Greif GB3 Weight: 34 pounds nominal Length: 45.75 inches nominal Width: 38.0 inches nominal Height: 39.75 inches nominal</p> <p>Production leak-tested per 49 CFR 178.801(f) at 3 psi</p>

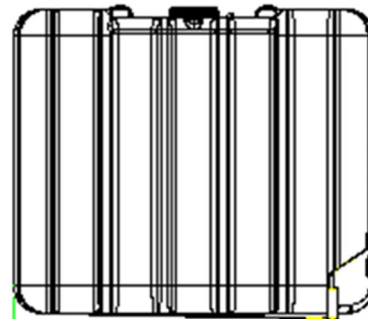

Length

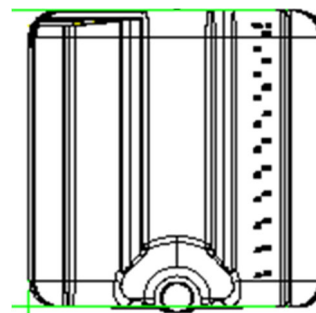

Width

Top Closure	<p>Type: 6" Cap with 2" Closure with Ventix Vent – Tamper Evident Fabrication: Injection molded</p>	<p>Cap & Plug Material: PE Gasket(s): EPDM</p>
Representative Service Equipment	<p>Type: 2" Quick Disconnect Screwable Valve Material: Polypropylene</p>	<p>Collar Gasket: Viton (FKM) Valve Seal Gasket(s): EPDM</p>
UN Qualification	Refer to UN test report for the structure it is installed into for proper UN marks	

DISTRIBUTED BY:



REF NO.:

DWG30433

DESCRIPTION:

275 Gallon Remanufactured IBC Tote, New Bottle

DISCLAIMER

THIS INFORMATION IS PROVIDED AS A GENERAL GUIDE, INCLUDING DIMENSIONS. IT IS THE CUSTOMER'S RESPONSIBILITIES TO SELECT THE PROPER CONTAINER FOR PRODUCT AND APPLICATION COMPATIBILITY.