

5.0 Gallon Rectangular Tight Head with Swing Handle

Product Uses

Liquid Products

Product Codes

Container: **RTH Series**

Description: 5.0G Rectangular Tighthead

Features

UN Rating: 3H1/Y1.8/100

Nominal capacity: 5.0 USG / 18.9L

Maximum capacity: 5.3 USG / 20.1 L

Tare weights: 2.71 lbs / 1.23 kgs

Colors

Standard: White, Black, Blue and Natural

Custom: Available at manufacturer's discretion

Decorating Options

Maximum Label Area:

Perimeter: 38-1/4" x 8-17/32" H

See Salesperson for Options

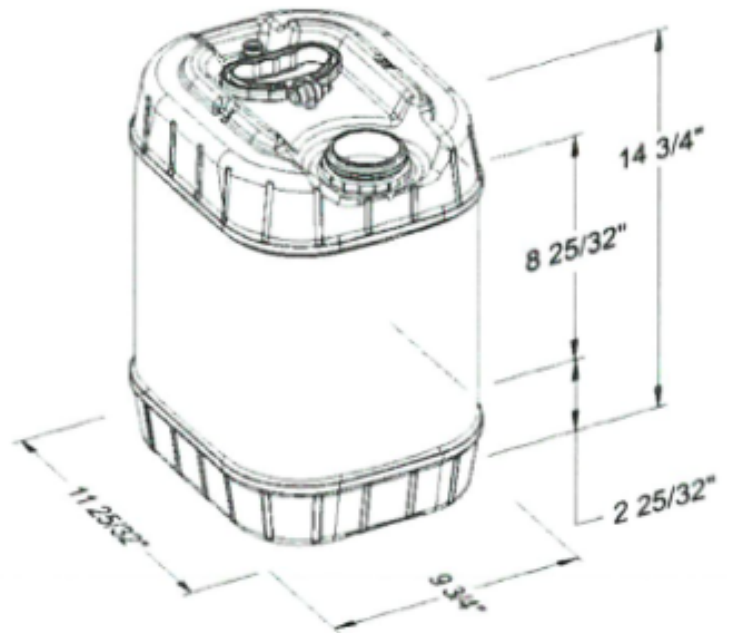

Shipping Data

Qty. per floor spot:

Containers

112

Gross Weight (lbs./kgs)*:

309 / 140

Length (in./cm.):

48 / 121

Width (in./cm.):

35.3 / 90

Height (in./cm.):

106 / 270

Estimated truckload quantity of 3,360 containers**

Notes: *Weight does not include pallet / packaging
**Truckload quantity based on 53' trailer

Materials

FDA approved materials

Resin: Body: High-Density Polyethylene (HDPE)

Handle/Pin: High-Density Polyethylene (HDPE)

MSDS Sheets available upon request

Optional Carrying Handle

Swing Handle with Pin

DISTRIBUTED BY:



REF NO.:

DWG30162

DISCLAIMER
THIS INFORMATION IS PROVIDED AS A GENERAL GUIDE, INCLUDING DIMENSIONS. IT IS THE CUSTOMER'S RESPONSIBILITIES TO SELECT THE PROPER CONTAINER FOR PRODUCT AND APPLICATION COMPATIBILITY.

DESCRIPTION:

5 Gallon Black HDPE Square Tight Head Pail, 63 mm & Closed Vent, UN Rated