

5.0 Gallon 90mil UN Pail with UN Cover

Multiple Uses

UN-liquids rated in US and Canada to 1.5 SpGr, 30kPa (Y1.5/30)
 UN Solids rated in US to Y43/S
 May also be used for non-hazardous liquids and solids.

Product Codes

Container: **5500 Series, 55100**
 Description: 5 gallon UN Pail

Cover: 2500 Series

Description: 5 gallon Standard UN Cover

Note: *Multiple fitting and venting options available

Features

Gauge: 90 mil.
 Nominal capacity: 5.0 USG / 19.0 L
 Stack performance: 350 lbs.*
 Tare weights: Body: 2.08 lbs. / .948 kgs
 Cover: .77 lbs. / .350 kgs.

Note: *Ratings will be reduced with uneven load distribution.

Specifications with Cover

Dimensions: 12-5/16" D X 14-11/16"H
 Maximum capacity: 5.3 USG / 20.2 L
 Tare weight: 2.85 lbs. / 1.29 kgs.

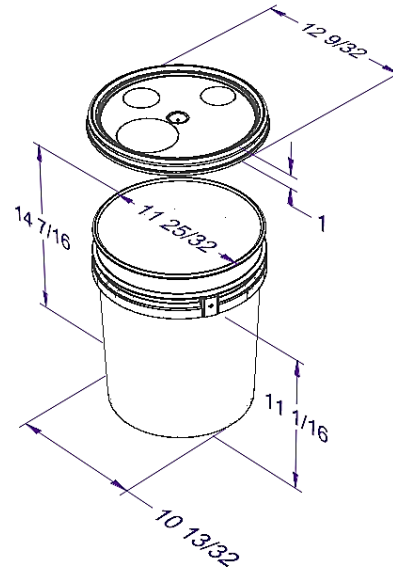

Colors

Standard: White, Black and Natural
 Custom: Available at manufacturer's discretion

Decorating Options

Four color offset printing
 Print area: 33"W x 8-1/2"H
 Sleeve or pressure sensitive labeling

Shipping Data

Qty. per pallet/carton:
 Gross Weight (lbs./kgs.)**:
 Length (in./cm.):
 Width (in./cm.):
 Height (in./cm.):

Bodies

240*
 499 / 226
 48 / 122
 36 / 91.4
 45 / 114

Covers

1,200*
 924 / 419
 49.5 / 126
 40 / 102
 97.5 / 248

Filled Containers

36 (12 per layer / 3 layers high)
 Pallet Height: 47"

Estimated truckload quantity of 5,520 bodies and covers***

Notes: *Quantity can vary based on customer request

**Weight does not include pallet/packaging

***Truckload quantity based on 53' trailer

Materials

FDA approved materials
 Resin: Body: High-Density Polyethylene (HDPE)
 Cover: High-Density Polyethylene (HDPE)

Optional Carrying Handle

Wire or Plastic

MSDS Sheets available upon request

DISTRIBUTED BY:



REF NO.:

DWG30159

DESCRIPTION:

5 Gallon White HDPE Open Head Pail UN

DISCLAIMER

THIS INFORMATION IS PROVIDED AS A GENERAL GUIDE, INCLUDING DIMENSIONS. IT IS THE CUSTOMER'S RESPONSIBILITIES TO SELECT THE PROPER CONTAINER FOR PRODUCT AND APPLICATION COMPATIBILITY.