

Features

Gauge: 100 mil.
Nominal capacity: 5.0 USG / 19.0 L
Stack performance: 350 lbs.*
Tare weights: Body: 2.31 lbs. / 1.050 kgs
Cover: .73 lbs. / .331 kgs.

Note: *Ratings will be reduced with uneven load distribution.

Specifications with Cover

Dimensions: 12-3/8" D X 14-11/16"H
Maximum capacity: 5.36 USG / 21.2 L
Tare weight: 3.04 lbs. / 1.38 kgs.

Colors

Standard: White, Black and Natural
Custom: Available at manufacturer's discretion

Decorating Options

Four color offset printing
Print area: 33"W x 8-1/2"H
Sleeve or pressure sensitive labeling

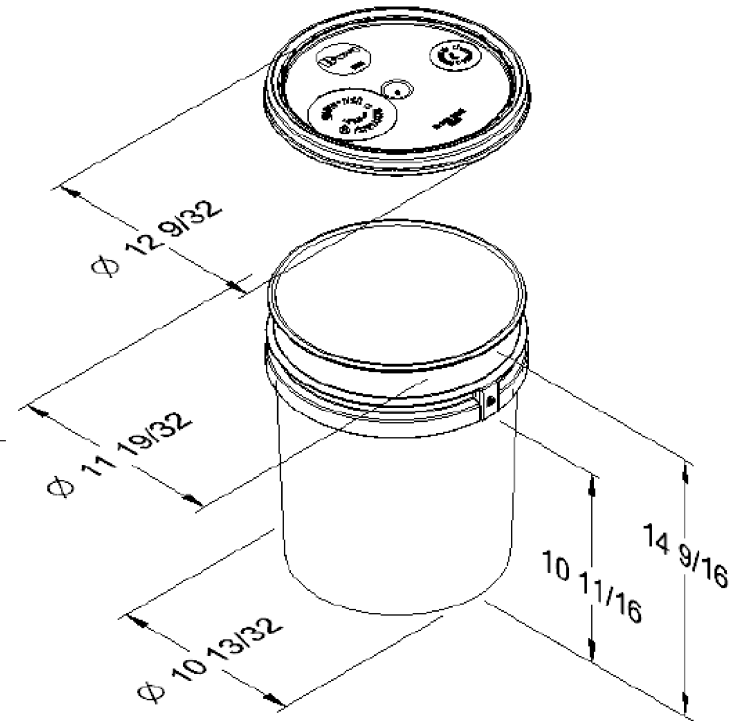

Shipping Data

Qty. per pallet/carton:
Gross Weight (lbs./kgs.)**:
Length (in./cm.):
Width (in./cm.):
Height (in./cm.):

Bodies

240*
420 / 190.5
48 / 122
36 / 91.4
45 / 114

Covers

1,200*
792 / 359
50 / 127
37.5 / 95.3
96 / 243.8

Filled Containers

36 (12 per layer / 3 layers high)
Pallet Height: 47"

Estimated truckload quantity of 5,520 bodies and covers***

Notes: *Quantity can vary based on customer request

**Weight does not include pallet/packaging

***Truckload quantity based on 53' trailer

Materials

FDA approved materials
Resin: Body: High-Density Polyethylene (HDPE)
Cover: High-Density Polyethylene (HDPE)

Optional Carrying Handle

Wire or Plastic

MSDS Sheets available upon request

DISCLAIMER

THIS INFORMATION IS PROVIDED AS A GENERAL GUIDE, INCLUDING DIMENSIONS. IT IS THE CUSTOMER'S RESPONSIBILITIES TO SELECT THE PROPER CONTAINER FOR PRODUCT AND APPLICATION COMPATIBILITY.

DISTRIBUTED BY:



DESCRIPTION:

5 Gal HDPE Open Head Pail

REF NO.:

DWG10415