

**Product Uses**

Liquid Products

**Features**

UN Rating: 3H1/Y1.8/100  
Nominal capacity: 5.0 USG / 18.9L  
Maximum capacity: 5.3 USG / 20.1 L  
Tare weights: 2.58 lbs / 1.17 kgs

**Colors**

Standard: White, Black, Blue and Natural  
Custom: Available at manufacturer's discretion

**Decorating Options**

Maximum Label Area:  
Perimeter: 38-1/4" x 8-1/4" H  
See Salesperson for Options

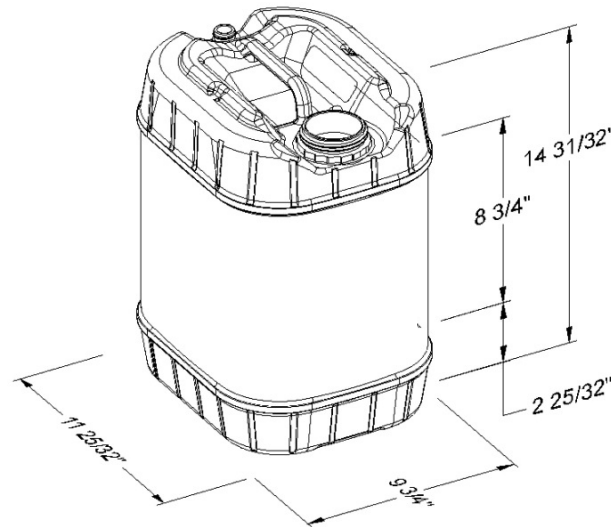

**Shipping Data**

Qty. per floor spot: 112  
Gross Weight (lbs./kgs)\*: 304 / 138  
Length (in./cm.): 47 / 118  
Width (in./cm.): 35.4 / 90  
Height (in./cm.): 108 / 274

**Containers**

Estimated truckload quantity of 3,360 containers\*\*

Notes: \*Weight does not include pallet / packaging  
\*\*Truckload quantity based on 53' trailer

**Materials**

FDA approved materials  
Resin: Body: High-Density Polyethylene (HDPE)

**Optional Carrying Handle**

Integral

MSDS Sheets available upon request

**DISCLAIMER**

THIS INFORMATION IS PROVIDED AS A GENERAL GUIDE, INCLUDING DIMENSIONS. IT IS THE CUSTOMER'S RESPONSIBILITIES TO SELECT THE PROPER CONTAINER FOR PRODUCT AND APPLICATION COMPATIBILITY.

DISTRIBUTED BY:



REF NO.:

DWG30466

DESCRIPTION:

5 Gallon White HDPE Tight Head, 70 mm