

**Product Uses**

Liquid Products

**Features**

UN Rating: 3H1/Y1.8/100  
Nominal capacity: 5.0 USG / 18.9L  
Maximum capacity: 5.3 USG / 20.1 L  
Tare weights: 2.71 lbs / 1.23 kgs

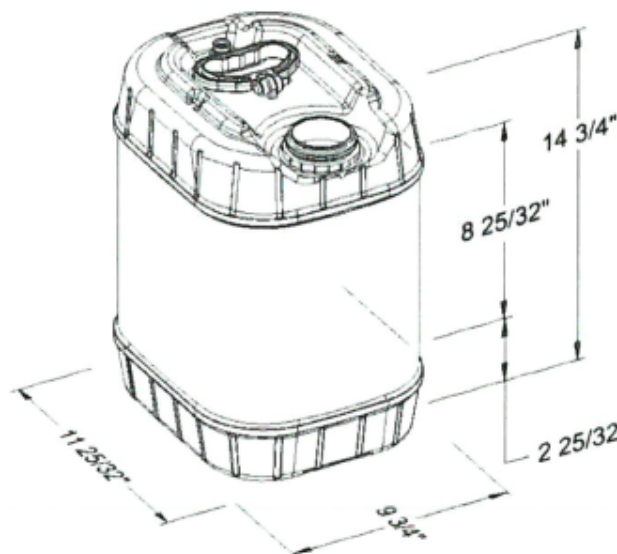

**Colors**

Standard: White, Black, Blue and Natural  
Custom: Available at manufacturer's discretion

**Decorating Options**

Maximum Label Area:  
Perimeter: 38-1/4" x 8-17/32" H  
See Salesperson for Options

**Shipping Data**

Qty. per floor spot:	112
Gross Weight (lbs./kgs)*:	309 / 140
Length (in./cm.):	48 / 121
Width (in./cm.):	35.3 / 90
Height (in./cm.):	106 / 270

**Containers**

**Filled Containers**

Refer to BWAY document # ETS-CD-1002 for storage and shipping recommendations.

Estimated truckload quantity of 3,360 containers\*\*

Notes: \*Weight does not include pallet / packaging  
\*\*Truckload quantity based on 53' trailer

**Materials**

FDA approved materials  
Resin: Body: High-Density Polyethylene (HDPE)  
Handle/Pin: High-Density Polyethylene (HDPE)

**Optional Carrying Handle**

Swing Handle with Pin

MSDS Sheets available upon request

**DISCLAIMER**

THIS INFORMATION IS PROVIDED AS A GENERAL GUIDE, INCLUDING DIMENSIONS. IT IS THE CUSTOMER'S RESPONSIBILITIES TO SELECT THE PROPER CONTAINER FOR PRODUCT AND APPLICATION COMPATIBILITY.

DISTRIBUTED BY:



REF NO.:

DWG30467

DESCRIPTION:

5 Gallon White HDPE Tight Head, Rieke Opening