

5 Gallon Round UN Container

Features

- UN Package for Liquid hazardous materials when used with 5LUND lid
- Universal container base for UN and non-UN applications
- Optimized height reduces spillage during filling and capping
- Heat transfer decoration and 6 color offset print capability
- Accepts plastic or metal handle

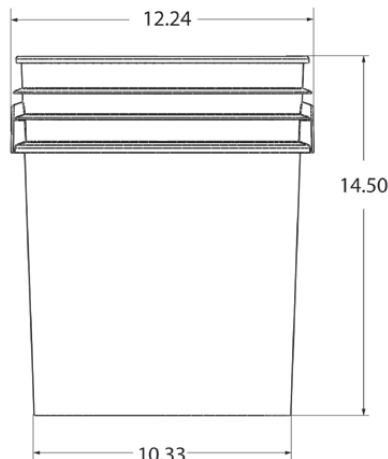

PRODUCT CODE.....5UND (TU5G90DMUNL)

COMPATIBLE LIDS..... 5LUND & 5LTB

SPECIFICATIONS

Height.....14.50"
 Outer Diameter.....12.24"
 Thickness.....90 mil
 Print Area.....31" x 8.25"
 Resin.....HDPE

VOLUME

Practical Fill w/ 5LUND.....5.00 gal. / 18.93 liters
 Practical Fill w/ 5LTBU or 5LTB.....5.30 gal. / 20.06 liters

WEIGHT

Pail Weight.....2.17 lbs

PACKAGING

Pack Count.....120
 Pack Dimensions.....48.9" x 36.6" x 49.6"
 Cubic Feet.....51.3
 Packs per Pallet.....2

ORDER QUANTITIES (53' Truckload)

5UND & 5LUND (UN Package)6,240 bases & lids
 5UND & 5LTB6,720 bases & lids

DISCLAIMER

THIS INFORMATION IS PROVIDED AS A GENERAL GUIDE, INCLUDING DIMENSIONS. IT IS THE CUSTOMER'S RESPONSIBILITIES TO SELECT THE PROPER CONTAINER FOR PRODUCT AND APPLICATION COMPATIBILITY.

DISTRIBUTED BY:



REF NO.:

DWG31037

DESCRIPTION:

5 Gallon HDPE OH Pail, UN Rated (5UND)