

Dimensions

(A) Fitting Centers	17.5"
(B) Outside Diameter (+/- 1/16")	23 13/16"
(C) Inside Diameter (+/- 1/16")	22.5"
(D) Height (+/- 1/8")	34 1/4"
Weight (+/-3%)	39.2 lb

Material

Head	1.2 mm CRCQ Steel
Body	0.9 mm CRCQ Steel
Bottom	1.2 mm CRCQ Steel

*All Steel tolerances conform to ISO3574

Head Fittings

Flanges	2"+2"+3/4" TS Plated with Buna
Plugs	2"+2"+3/4" TS Plated with Poly
Capseals	No

Closing Ring

Ring	12 GA SQ Forged Lug
Bolt, Nut	5/8"X4" cross-drilled with Nylok patch
Gasket	7/16" EPDM

Interior

Coating	RI Rust Inhibitor
---------	-------------------

Exterior Coating

Top	White
A Panel	Black
B Panel	Black
C Panel	Black
Bottom	Gray Recycle

Silkscreen

No

Embossing

UN1A2/Y1.5/120	1A2/Y300/S	1.2/0.9/1.2
----------------	------------	-------------

Inkjet

UN1A2/Y1.5/100	1A2/Y300/S	M4601	JD
----------------	------------	-------	----

Special Instructions

2" and 3/4" tightened.

Notes: The photo shown below may or may not be identical to the description given.

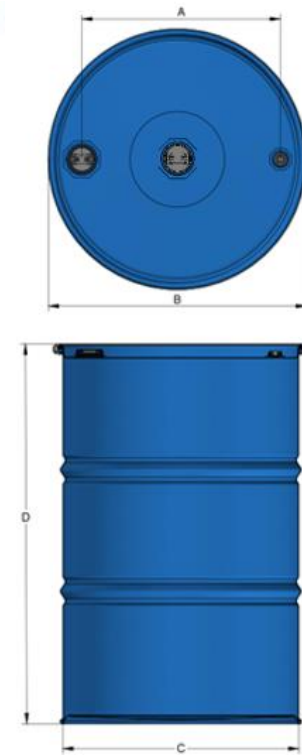

DISTRIBUTED BY:



REF NO.:

DWG30478

DESCRIPTION:

55 Gallon Black Steel Open Head with 2" Center Fitting,
Unlined

DISCLAIMER

THIS INFORMATION IS PROVIDED AS A GENERAL GUIDE, INCLUDING DIMENSIONS. IT IS THE CUSTOMER'S RESPONSIBILITIES TO SELECT THE PROPER CONTAINER FOR PRODUCT AND APPLICATION COMPATIBILITY.