

Product Uses

Liquid Products

Features

UN Rating: 3H1/Y1.5/100
Nominal capacity: 7.0 USG / 26.5L
Maximum capacity: 7.4 USG / 28.1 L
Tare weights: 3.28 lbs / 1.49 kgs

Colors

Standard: White, Black, Blue and Natural
Custom: Available at manufacturer's discretion

Decorating Options

Maximum Label Area:
Perimeter: 38-1/4" x 13-11/16" H
See Salesperson for Options

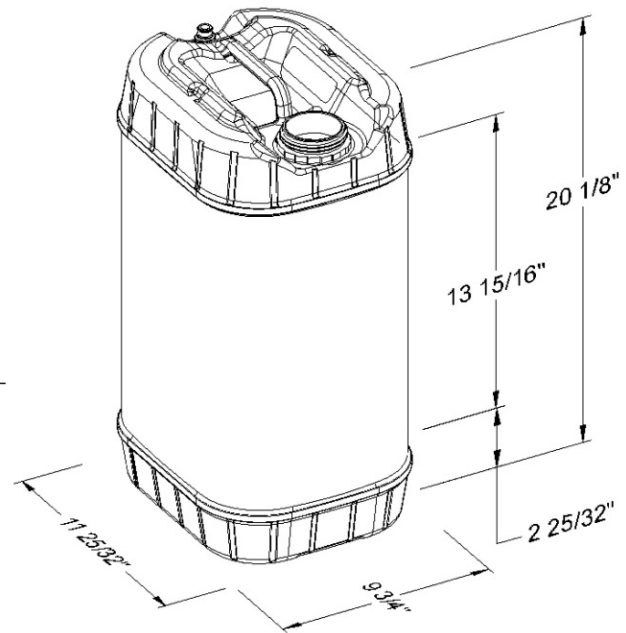

Shipping Data

Qty. per floor spot: 80
Gross Weight (lbs./kgs)*: 263 / 119
Length (in./cm.): 47 / 118
Width (in./cm.): 35.4 / 90
Height (in./cm.): 105 / 266

Containers

Estimated truckload quantity of 2,400 containers**

Notes: *Weight does not include pallet / packaging
**Truckload quantity based on 53' trailer

Materials

FDA approved materials
Resin: Body: High-Density Polyethylene (HDPE)

MSDS Sheets available upon request

Optional Carrying Handle

Integral

DISTRIBUTED BY:



REF NO.:

DWG30495

DESCRIPTION:

7 Gallon Blue HDPE Tight Head, 70 mm

DISCLAIMER

THIS INFORMATION IS PROVIDED AS A GENERAL GUIDE, INCLUDING DIMENSIONS. IT IS THE CUSTOMER'S RESPONSIBILITIES TO SELECT THE PROPER CONTAINER FOR PRODUCT AND APPLICATION COMPATIBILITY.