

3/4 - 14 THREAD

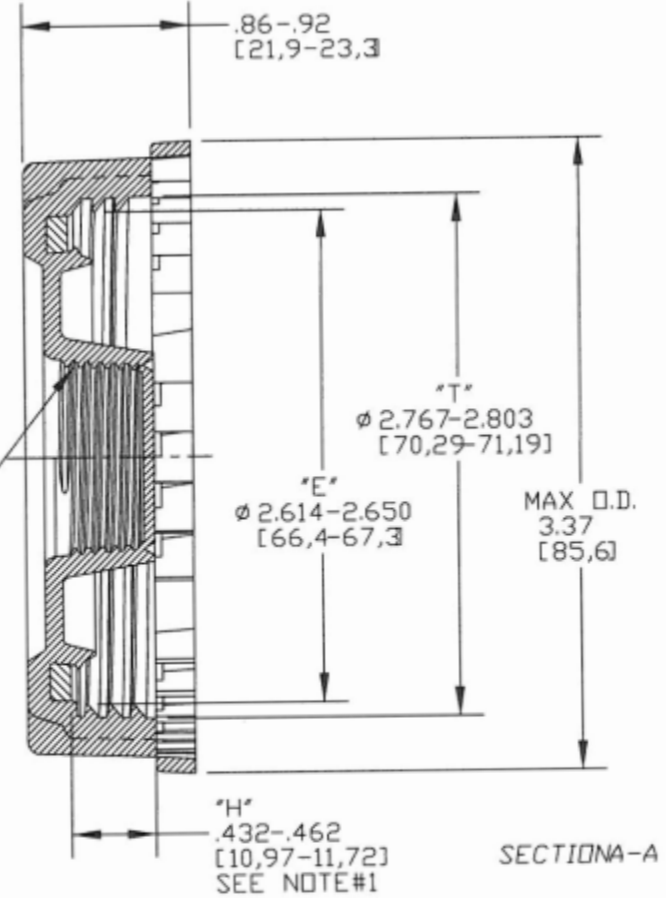

- NOTES:
 1) EFFECTIVE "H" IS ESTABLISHED BY SUBTRACTING GASKET THICKNESS FROM OVERALL "H".
 2) MATERIALS USED MEET FDA REQUIREMENTS.
 3) 8 TPI .125 PITCH

DISCLAIMER

THIS INFORMATION IS PROVIDED AS A GENERAL GUIDE, INCLUDING DIMENSIONS. IT IS THE CUSTOMER'S RESPONSIBILITIES TO SELECT THE PROPER CONTAINER FOR PRODUCT AND APPLICATION COMPATIBILITY.

DISTRIBUTED BY: Pipeline Packaging

REF NO.: DWG30502

DESCRIPTION: DescriptionDescriptionDescriptionDescriptionDescription