

DETAIL A
SCALE 1/1

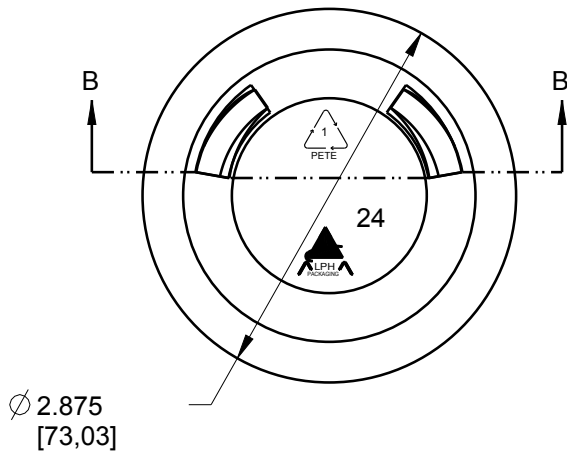

Neck Dimensions:	
T	= 2.718±.018
E	= 2.624±.018
H	= .408±.015
I	= 2.247 MIN
S	= .046±.015

Overflow Capacity: 286 ml ± 7

DISCLAIMER

THIS INFORMATION IS PROVIDED AS A GENERAL GUIDE, INCLUDING DIMENSIONS. IT IS THE CUSTOMER'S RESPONSIBILITIES TO SELECT THE PROPER CONTAINER FOR PRODUCT AND APPLICATION COMPATIBILITY.

DISTRIBUTED BY:



REF NO.:

DWG30527

DESCRIPTION:

8 oz Clear PET Wide Mouth Jar, 70-400