

NOTES:

1) CAPS ARE PRODUCED ACCORDING TO CMA STANDARDS AND ARE SUITABLE FOR GLASS FINISH GPI 83-400

2) DIMENSION OF THREAD INTERNAL DIAMETER TAKEN WITH A PLUG GAGE

3) MIN. PLASTISOL THICKNESS 0.025" IF APPLICABLE

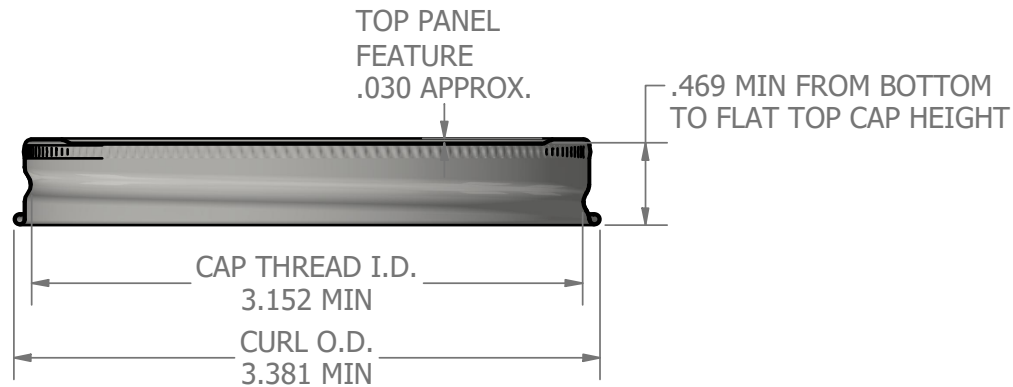
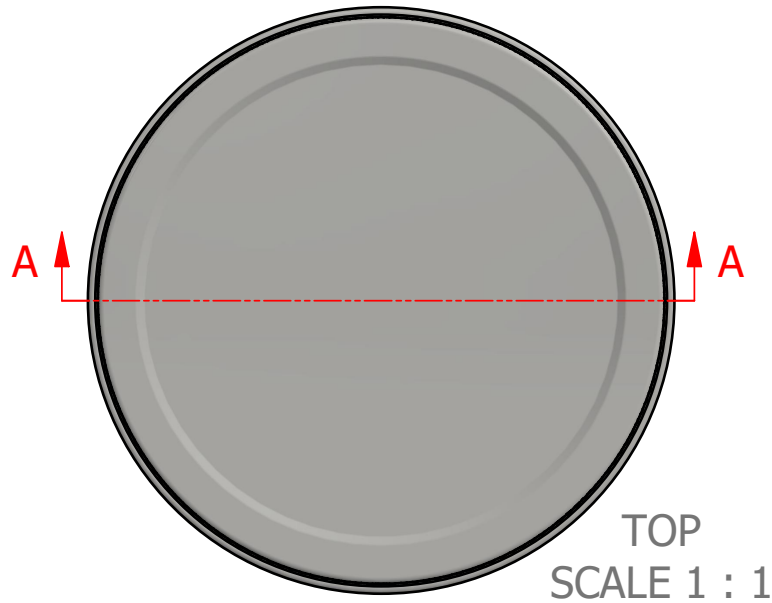

SECTION A-A
SCALE 1 : 1

DISCLAIMER

THIS INFORMATION IS PROVIDED AS A GENERAL GUIDE, INCLUDING DIMENSIONS. IT IS THE CUSTOMER'S RESPONSIBILITIES TO SELECT THE PROPER CONTAINER FOR PRODUCT AND APPLICATION COMPATIBILITY.

DISTRIBUTED BY:



REF NO.:

DWG30532

DESCRIPTION:

83-400 White Metal Cap with Plastisol Liner