

38mm REXAM NBO NECK DETAIL  
(PER REXAM SPEC # M 6961H)  
1) THREAD START 45° FROM FL IN PIN HALF  
2) 1.5 TURNS (540°) OF THREAD  
3) PITCH = .167"  
4) 6 THREADS PER INCH

VOLUMETRIC ENGRAVING  
.200 TALL TEXT  
CENTERED ON MARK  
RAISED .008-.010  
LOCATIONS T.B.D.

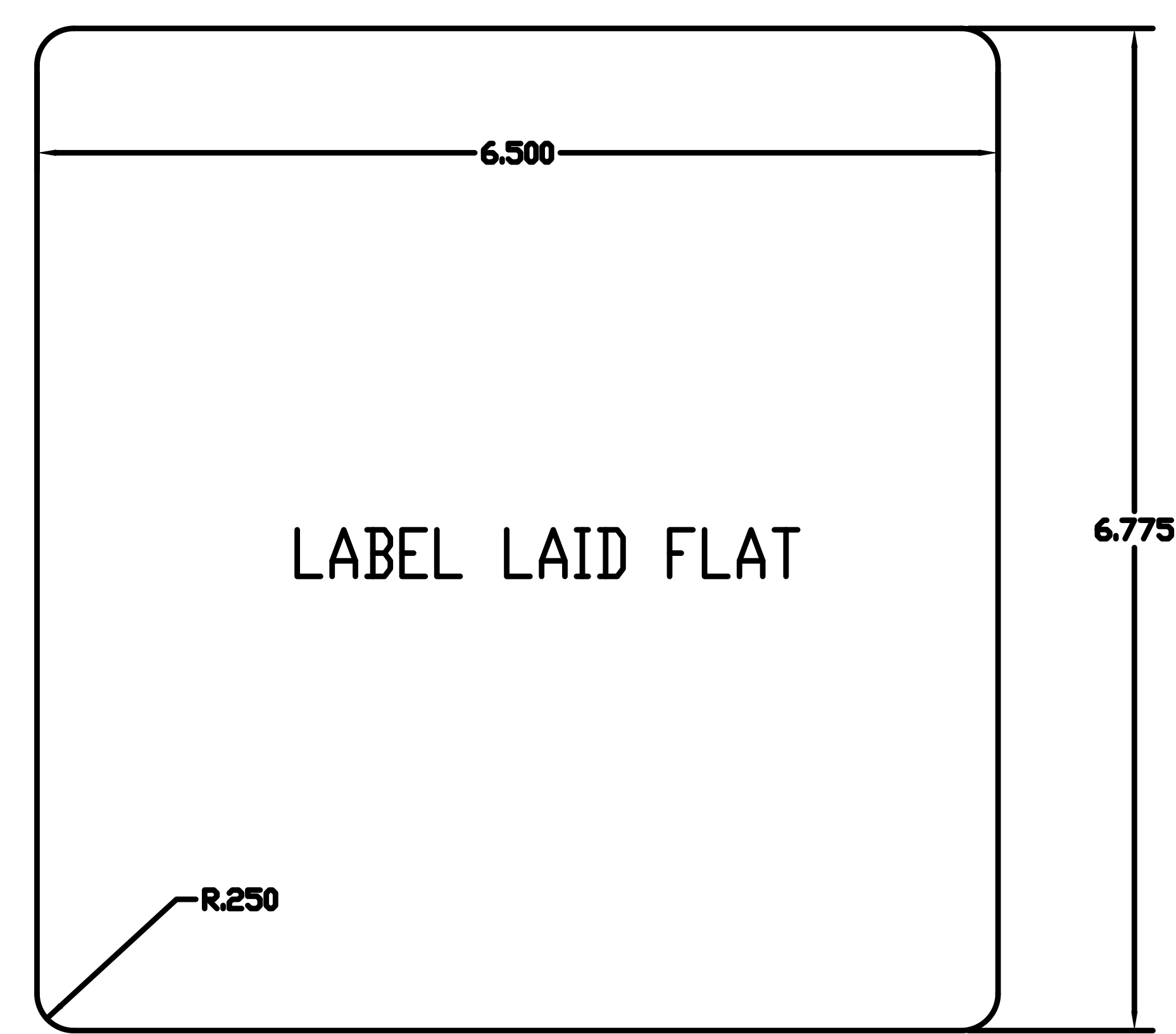
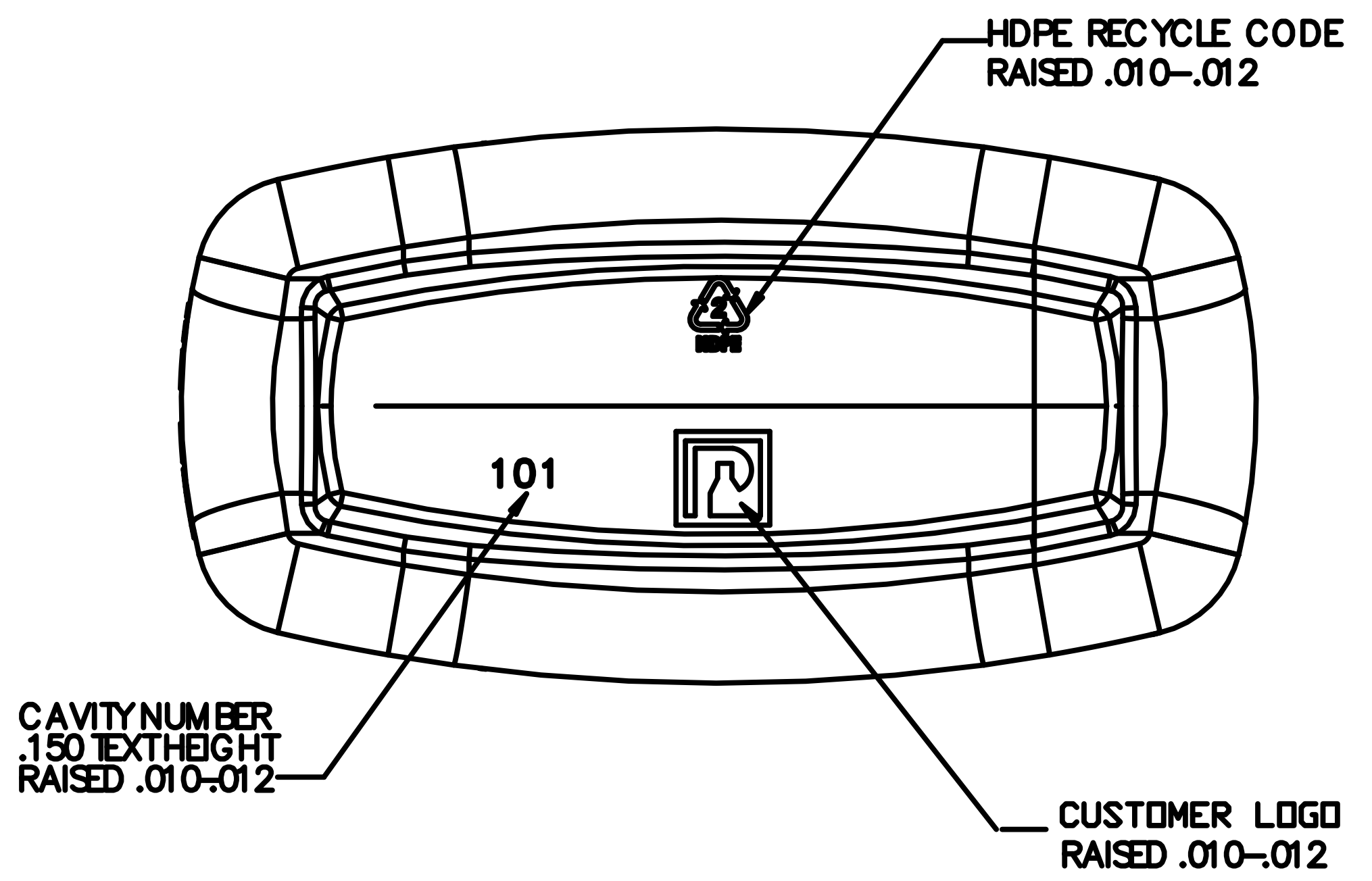

Container Data	
Weight	126 grams ± 6 Grams
Fill Level Capacity	128 oz
Overflow Capacity	142.6 oz
Material	HDPE
Estimated Bulge	3.2 oz.

**DISCLAIMER**  
THIS INFORMATION IS PROVIDED AS A GENERAL GUIDE, INCLUDING DIMENSIONS. IT IS THE CUSTOMER'S RESPONSIBILITIES TO SELECT THE PROPER CONTAINER FOR PRODUCT AND APPLICATION COMPATIBILITY.

DISTRIBUTED BY: PIPELINE Packaging  
DESCRIPTION: 4 Liter Green HDPE Plastic F Style Bottle, 38-400, 165 Gram  
REF NO.: DWG31189