

Specification

NO.	PART NAME	MATERIAL
1	DSCHARGE VALVE	LDPE
2	VALVE BODY	PP
3	SPRING	SUS (304)
4	NOZZLE	PP
5	PISTON	LDPE
6	VALVE BALL	SUS (304)
7	SHROUD	PP
8	TUBE RETAINER	PP
9	TRIGGER	PP
10	GASKET	PE FOAM
11	CLOSURE (28/400)	PP
12	DP TUBE	PE

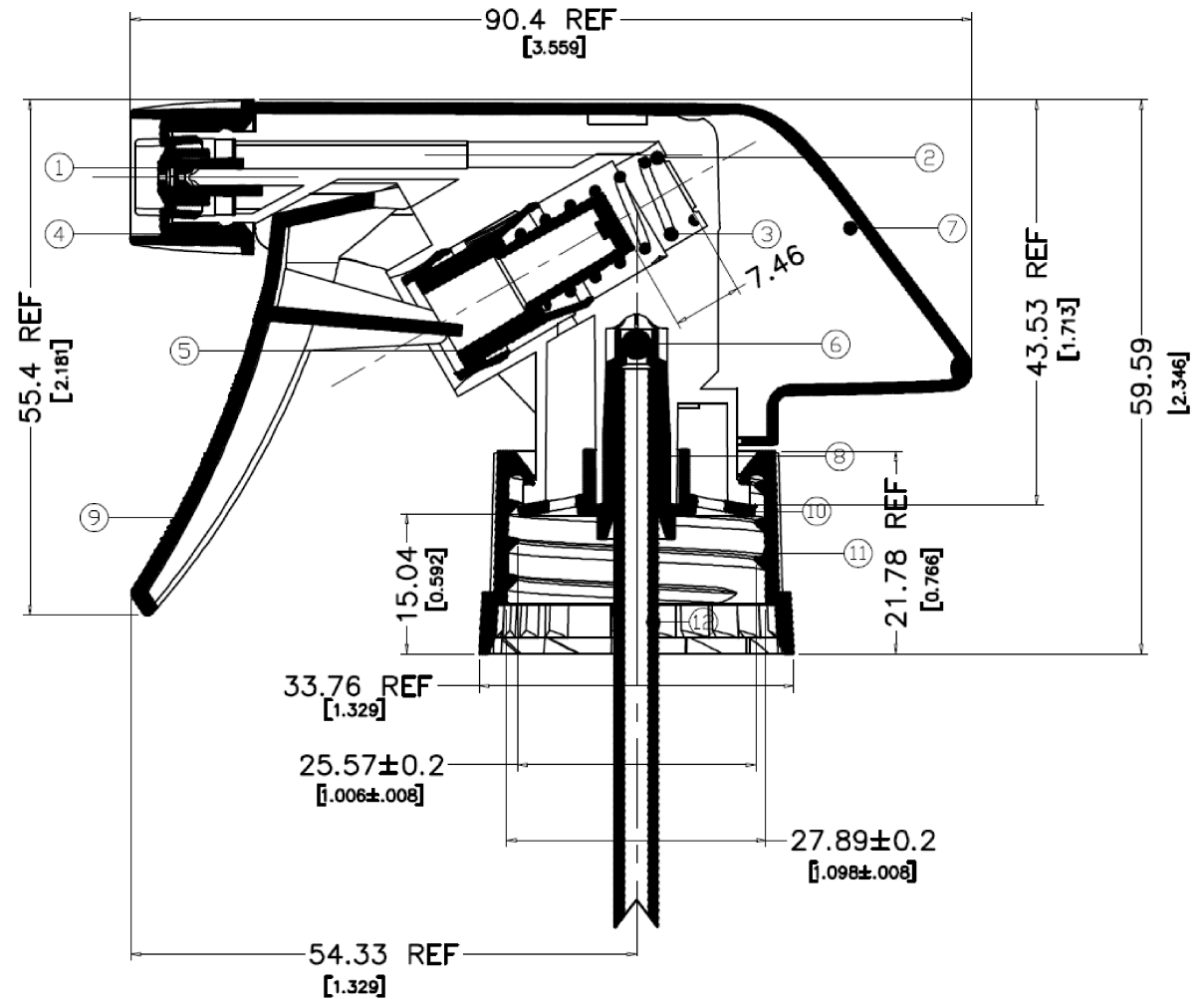

DOSAGE; 0.8±0.1CC

DISCLAIMER

THIS INFORMATION IS PROVIDED AS A GENERAL GUIDE, INCLUDING DIMENSIONS. IT IS THE CUSTOMER'S RESPONSIBILITIES TO SELECT THE PROPER CONTAINER FOR PRODUCT AND APPLICATION COMPATIBILITY.

DISTRIBUTED BY:



REF NO.:

DWG30034

DESCRIPTION:

28-400 Trigger Sprayer