

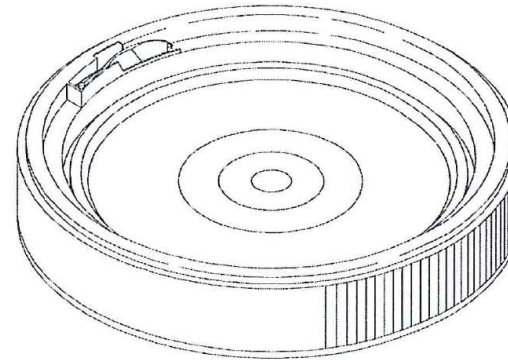

Prepared For: Standard Technical Specification  
09/06/11

**General Specifications for cover:**

**Material:** High Density Polyethylene (HDPE)  
**Method of Mfg:** Injection Molding  
**Weight:** .75 lbs  
**Cover Height:** 2.41"  
**Min. Wall Thickness:** .075" (75 mil)  
**Bottom OD:** 11.72"  
**Qty:** 240 per pallet  
**Standard Color:** White, Red186, Blue300  
 Please inquire about custom colors



Top ID: 10.08 "

**General Specifications for Pail:**

**Material:** High Density Polyethylene (HDPE)  
**Method of Mfg:** Injection Molding  
**Nominal Capacity:** 2.5 Gallons  
**Weight:** 1.34 lbs  
**Min. Wall Thickness:** .075" (75 mil)  
**Exterior Height:** 9.80"  
**Top ID:** 10.08"  
**Bottom OD:** 9.40 "  
**Shipping: Case:** 8 pails and lids per case  
**Pallet:** 168 units  
**Truckload:** 5,208 units  
**Handle:** Plastic Handle  
**Printing Area:** 5" x 29.75"  
**Nesting:** Tapered walls for nesting  
**Standard Color:** White  
 Please inquire about custom colors  
**UN Certification:** 1H2/Y19/S

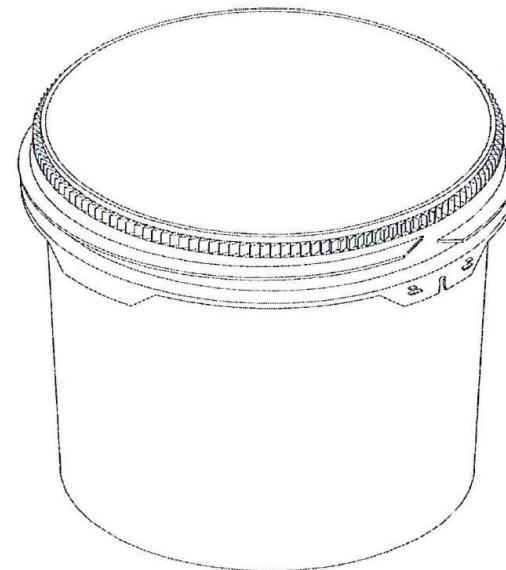

Height  
9.80"

Height  
w/cover  
10.15"

Bottom OD: 9.40"

**DISCLAIMER**

THIS INFORMATION IS PROVIDED AS A GENERAL GUIDE, INCLUDING DIMENSIONS. IT IS THE CUSTOMER'S RESPONSIBILITIES TO SELECT THE PROPER CONTAINER FOR PRODUCT AND APPLICATION COMPATIBILITY.

DISTRIBUTED BY:



REF NO.:

DWG20628

DESCRIPTION:

2.5 gallon HDPE Screw Top Pail